

LEMPCO®

Manufacturing With The Highest
Precision Level Available

NEW LOOK, SAME TRADITION

INTRODUCTION

LEMPCO®

LEMPCO is proud to introduce our new all-inclusive premium product catalog! This new catalog incorporates numerous upgrades to the brand, specifically product improvements, superior appearance and a new logo. With a bold and modern statement created for the brand, this catalog has been color-coded to easily locate product information.

As an internationally recognized manufacturer of guidance systems, LEMPCO has been servicing major industries, including canning, electronics, automotive, appliance, plastics, computer and specialty items, since 1918. Long recognized as the standard for excellence in the industry, and known by our extremely high quality and reliability, LEMPCO products are in demand worldwide.

PRODUCT IMPROVEMENTS

Always working hard to bring new solutions to customers, LEMPCO Ball Cages have been completely redesigned with several product improvements. The newly improved orbital staking enhances the reliability of ball bearing retention and prevents the loss of ball bearings during use. The Ball Cages are now black anodized to provide a protective hard coating which improves function and helps eliminate material flaking during operation. We have also added additional bearings on each retainer which increases bearing surface. These improved Ball Cages allow metal stampers to achieve high-speed press production with less frequent replacements, thus avoiding costly downtime. Overall, the orbital staking lowers the Ball Cage stress levels during production and improves the operational life cycle performance.

SAME INDUSTRY TRADITIONS

Although we have a new look, LEMPCO uses the same traditions we have always had. We pledge that all LEMPCO products, innovative or conventional, will be manufactured to the same high level of accuracy you have always known. To ensure you are receiving the high quality you expect from us, we stamp the LEMPCO name on every part we manufacture, which means satisfaction in terms of quality, dependability and service. The pride we have in our ability to perform and provide you with profitable production with our die sets and components is the foundation of our business.

CUSTOMER SATISFACTION

Backed by years of experience and a renewed commitment to our customers, LEMPCO understands customer needs and ensures cost-effective products and complete satisfaction. We recognize the value of maintaining relationships and can help meet the needs of quick deliveries, competitive prices and high quality parts. Our extensive LEMPCO distribution network, sales personnel and technical engineers will work closely with you to make sure your specifications are met.

CAD FILES

LEMPCO component product line is now available on-line in 2D/3D CAD formats. To download the templates, visit our website at www.daytonlamina.com.

New
Ball Cage:
Orbital
Stake



Old
Ball Cage:
Two-Point
Stake



LEMPCO guidance systems are considered the quality standard in can making dies and tooling systems worldwide. Find out how our new enhancements of our Retainer/Rotainer® products can improve your performance.

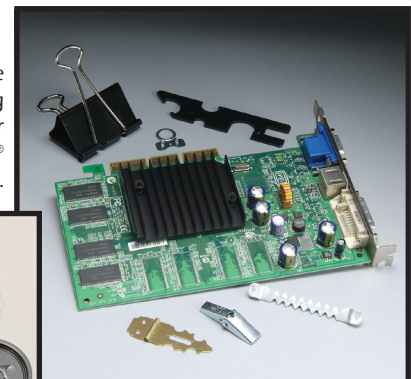

LEMPCO PRODUCTS

Pins & Bushings – Inch -----	2
Engineering & Technical Data-----	13
Plain Bearing Bushings -----	18

Pins & Bushings – Metric -----	20
Engineering Data -----	28

Die Springs -----	29
Accessories-----	38
Spring Cages, Spring Retainers	

Specialty Items -----	40
-----------------------	----

THE LEMPCO VALUE PROPOSITION

LEMPCO is a recognized leader in providing quality ball bearing components:

- 1. Rotainer® designed ball cage that minimizes tracking.
- 2. Precision Rotainer® and retainer that provides accuracy and repeatability in high speed applications.
- 3. Quality pins and bushings are made from 52100 tool steel and are precision ground.

LEMPCO has a strong distribution network located around the world to service our valued customers.



QUALITY · DEPENDABILITY · SERVICE

SINCE 1918

THE GLOBAL STANDARD WITH DISTRIBUTORS WORLDWIDE

ROTAINERS® FOR BALL BEARING APPLICATIONS

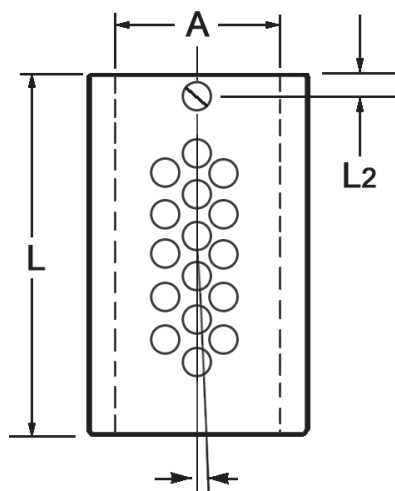

Radial bearing placement reduces wear and tracking.

Designed to rotate on the post, as well as maintain its vertical motion, LEMPCO ROTAINERS® were developed to greatly reduce the amount of tracking. The disengagement of the guide post from the bushing by 1/4" at the top of the stroke will allow the ROTAINER® to rotate 360° on the guide post. The ROTAINER®, while still designed to track, (assuring a measurable amount of preload) will enable stampers to achieve high press production by reducing expensive replacement costs.

Rotainer® Slide Replacement With Screw Assembly		Number of Inserts
Nom.	Assembly Part Number	
3/4	06CLIP	1
1	08CLIP	1
1 1/4	10CLIP	1
1 1/2	12CLIP	1
1 3/4	14CLIP	1
2	16CLIP	2
2 1/2	20CLIP	2
3	24CLIP	2

NOTES:

Diameters and lengths not listed are available by special order.
 The LAST length for each diameter shown in the table at right should be used for general die set applications. Other lengths are for limited space and special applications.
 Under a preloaded condition, the ROTAINER® will only move vertically.

Nom. Post Diameter A	Length (in) L	Set Screw (in) L2	Catalog Number
3/4	1 1/2	0.307	361-0606
	1 3/4		361-0607
	2		361-0608
	2 1/4		361-0609
	2 1/2		361-0610
1	1 1/2		361-0806
	1 3/4		361-0807
	2		361-0808
	2 1/4		361-0809
	2 1/2		361-0810
1 1/4	2	0.419	361-1008
	2 1/4		361-1009
	2 1/2		361-1010
	2 3/4		361-1011
	3		361-1012
1 1/2	3 1/4		361-1013
	2 1/2		361-1210
	2 3/4		361-1211
	3		361-1212
	3 1/4		361-1213
1 3/4	3 1/2		361-1214
	3 3/4		361-1215
	2 3/4		361-1411
	3		361-1412
	3 1/4		361-1413
2	3 1/2	361-1414	
	3 3/4	361-1415	
	4	361-1416	
	4 1/4	361-1417	
	4 1/2	361-1613	
2 1/2	3 1/2	361-1614	
	3 3/4	361-1615	
	4	361-1616	
	4 1/4	361-1617	
	4 1/2	361-1618	
3	3 1/4	361-2013	
	4	361-2016	
	4 1/2	361-2018	
	5	361-2020	
	6	361-2024	
3	6 1/2	361-2026	
	7	361-2028	
	5	361-2420	
3	6	361-2424	
	7	361-2428	

PRECISION BALL BEARING RETAINERS FOR BALL BEARING APPLICATIONS

Nom. Post Diameter A	Length (in) L	Set Screw (in) L2	Catalog Number
3/4	1 1/2	0.250	931-0606
	1 3/4		931-0607
	2		931-0608
	2 1/4		931-0609
	2 1/2		931-0610
1	1 1/2		931-0806
	1 3/4		931-0807
	2		931-0808
	2 1/4		931-0809
	2 1/2		931-0810
1 1/4	2		931-1008
	2 1/4		931-1009
	2 1/2		931-1010
	2 3/4		931-1011
	3		931-1012
	3 1/4		931-1013
1 1/2	2 1/2		931-1210
	2 3/4		931-1211
	3		931-1212
	3 1/4		931-1213
	3 1/2		931-1214
	3 3/4		931-1215
1 3/4	2 3/4		931-1411
	3		931-1412
	3 1/4		931-1413
	3 1/2		931-1414
	3 3/4		931-1415
	4		931-1416
2	4 1/4	931-1417	
	3 1/4	931-1613	
	3 1/2	931-1614	
	3 3/4	931-1615	
	4	931-1616	
	4 1/4	931-1617	
2 1/2	4 1/2	931-1618	
	3 1/4	0.313	931-2013
	4		931-2016
	4 1/2		931-2018
	5		931-2020
	6		931-2024
	6 1/2		931-2026
7	931-2028		
3	5	931-2420	
	6	931-2424	
	7	931-2428	

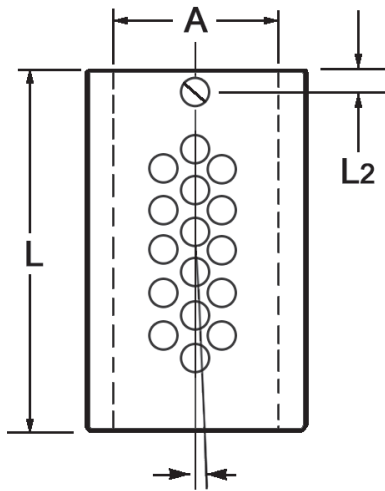

Radial bearing placement reduces wear and tracking.



LEMPCO Precision Ball Bearing Retainers possess resistance to normal wear and to lateral motion, are smooth in high speed operation and offer precise die register. They are keyed to the guide post slot with a set screw.

Retainer* Slide Replacement With Screw Assembly		Number of Set Screws
Nom.	Set Screw Part Number	
3/4	SETSCREW 101214	1
1	SETSCREW 101214	1
1 1/4	SETSCREW 162024	1
1 1/2	SETSCREW 162024	1
1 3/4	SETSCREW 162024	1
2	SETSCREW 162024	2
2 1/2	SETSCREW 162024	2
3	SETSCREW 162024	2

NOTE:

The LAST length for each diameter shown in the above table should be used for general die set applications. Other lengths are for limited space and special applications.

DEMOUNTABLE STEEL GUIDE POST BUSHINGS FOR BALL BEARING APPLICATIONS



LEMPCO Demountable Guide Post Bushings are manufactured from 52100 tool steel and precision machined. Diameters and lengths not listed are available by special order. Required clamps and screws are included.

3 clamps & screws provided for diameters up through 1.5".

4 clamps & screws provided for diameters 1.75" and larger.

Nom. Post Diameter	B	C	C1	E	F	Radius		L	Catalog Number
						M	N		
1	1.7154	2	2.0000	1	7/8	1.219	1.594	1 7/8	962-0808
					1 1/8			2 1/8	962-0809
					1 3/8			2 3/8	962-0810
					1 5/8			2 5/8	962-0811
					1 7/8			2 7/8	962-0812
					2 1/8			3 1/8	962-0813
					2 3/8			3 3/8	962-0814
					2 5/8			3 5/8	962-0815
1 1/4	2.1054	2 3/8	2.360	1	1 3/8	1.442	1.864	2 3/8	962-1010
					1 5/8			2 5/8	962-1011
					1 7/8			2 7/8	962-1012
					2 1/8			3 1/8	962-1013
					2 3/8			3 3/8	962-1014
					2 5/8			3 5/8	962-1015
					2 7/8			3 7/8	962-1016
					3 1/8			4 1/8	962-1017
					3 3/8			4 3/8	962-1018
					3 7/8			4 7/8	962-1020
					4 3/8			5 3/8	962-1022
					4 7/8			5 7/8	962-1024
1 1/2	2.4354	2 11/16	2.500	1 1/4	1 5/8	1.598	2.020	2 7/8	962-1212
					1 7/8			3 1/8	962-1213
					2 1/8			3 3/8	962-1214
					2 3/8			3 5/8	962-1215
					2 5/8			3 7/8	962-1216
					2 7/8			4 1/8	962-1217
					3 1/8			4 3/8	962-1218
					3 3/8			4 5/8	962-1219
					3 5/8			4 7/8	962-1220
					3 7/8			5 1/8	962-1221
					4 1/8			5 3/8	962-1222
					4 5/8			5 7/8	962-1224
1 3/4	2.7454	3	2.875	1 1/4	1 5/8	1.754	2.176	2 7/8	962-1412
					2 1/8			3 3/8	962-1414
					2 3/8			3 5/8	962-1415
					2 5/8			3 7/8	962-1416

DEMOUNTABLE STEEL GUIDE POST BUSHINGS FOR BALL BEARING APPLICATIONS

Nom. Post Diameter	B	C	C1	E	F	Radius		L	Catalog Number
						M	N		
1 3/4	2.7454	3	2.875	1 1/4	2 7/8	1.754	2.176	4 1/8	962-1417
					3 1/8			4 3/8	962-1418
					3 3/8			4 5/8	962-1419
					3 5/8			4 7/8	962-1420
					3 7/8			5 1/8	962-1421
					4 1/8			5 3/8	962-1422
					4 5/8			5 7/8	962-1424
					5 1/8			6 3/8	962-1426
					5 5/8			6 7/8	962-1428
					6 1/8			7 3/8	962-1430
2	3.1604	3 9/16	3.375	1 1/4	1 5/8	2.035	2.457	2 7/8	962-1612
					2 1/8			3 3/8	962-1614
					2 3/8			3 5/8	962-1615
					2 5/8			3 7/8	962-1616
					2 7/8			4 1/8	962-1617
					3 1/8			4 3/8	962-1618
					3 3/8			4 5/8	962-1619
					3 5/8			4 7/8	962-1620
					3 7/8			5 1/8	962-1621
					4 1/8			5 3/8	962-1622
					4 5/8			5 7/8	962-1624
					5 1/8			6 3/8	962-1626
					5 5/8			6 7/8	962-1628
					6 1/8			7 3/8	962-1630
2 1/2	3.6804	4 1/16	4.063	1 1/4	3 5/8	2.259	2.681	4 7/8	962-2020
					4 1/8			5 3/8	962-2022
					4 5/8			5 7/8	962-2024
					5 1/8			6 3/8	962-2026
					5 5/8			6 7/8	962-2028
					6 1/8			7 3/8	962-2030
3	4.1804	4 9/16	4.500	1 1/4	3 5/8	2.531	2.953	4 7/8	962-2420
					4 1/8			5 3/8	962-2422
					4 5/8			5 7/8	962-2424
					5 1/8			6 3/8	962-2426
					5 5/8			6 7/8	962-2428
					6 1/8			7 3/8	962-2430

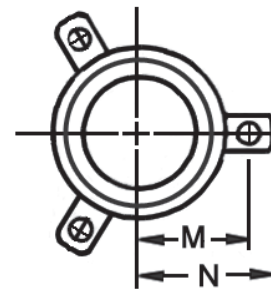
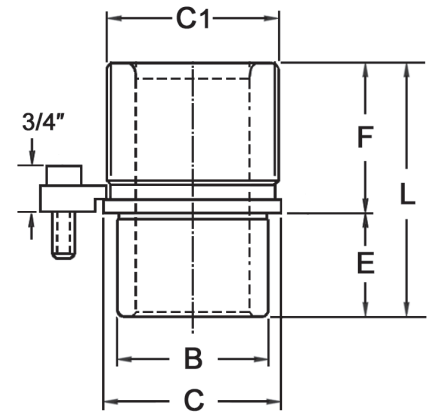

NOTE:

The "C" dimension measurement is from the outside edge of the flange to the opposite outside edge.

SHOULDER GUIDE POST BUSHINGS

FOR BALL BEARING APPLICATIONS



Nom. Post Diameter	B	C	C1	E	F	Radius		L	Catalog Number
						M	N		
1	1.725	2	2.000	1	7/8	1.219	1.594	1 7/8	963-0808
					1 1/8			2 1/8	963-0809
					1 3/8			2 3/8	963-0810
					1 5/8			2 5/8	963-0811
					1 7/8			2 7/8	963-0812
					2 1/8			3 1/8	963-0813
					2 3/8			3 3/8	963-0814
					2 5/8			3 5/8	963-0815
1 1/4	2.115	2 3/8	2.360	1	1 3/8	1.442	1.864	2 3/8	963-1010
					1 5/8			2 5/8	963-1011
					1 7/8			2 7/8	963-1012
					2 1/8			3 1/8	963-1013
					2 3/8			3 3/8	963-1014
					2 5/8			3 5/8	963-1015
					2 7/8			3 7/8	963-1016
					3 1/8			4 1/8	963-1017
					3 3/8			4 3/8	963-1018
					3 7/8			4 7/8	963-1020
					4 3/8			5 3/8	963-1022
					4 7/8			5 7/8	963-1024
1 1/2	2.445	2 11/16	2.500	1 1/4	1 5/8	1.598	2.020	2 7/8	963-1212
					1 7/8			3 1/8	963-1213
					2 1/8			3 3/8	963-1214
					2 3/8			3 5/8	963-1215
					2 5/8			3 7/8	963-1216
					2 7/8			4 1/8	963-1217
					3 1/8			4 3/8	963-1218
					3 3/8			4 5/8	963-1219
					3 5/8			4 7/8	963-1220
					3 7/8			5 1/8	963-1221
					4 1/8			5 3/8	963-1222
					4 5/8			5 7/8	963-1224

Shoulder Guide Post Bushings are manufactured from 52100 tool steel and precision ground. They are similar to LEMPCO Steel Demountable Bushings but are a minimum of .008" larger on the mounting diameter, corresponding to the additional material on the Shoulder Guide Post. They may be installed either by tap or press fitting. These bushings are interchangeable. See pages 13–15 for mounting instructions.

Required clamps and screws are included.

SHOULDER GUIDE POST BUSHINGS FOR BALL BEARING APPLICATIONS

Nom. Post Diameter	B	C	C1	E	F	Radius		L	Catalog Number
						M	N		
1 3/4	2.755	3	2.875	1 1/4	1 5/8	1.754	2.176	2 7/8	963-1412
					2 1/8			3 3/8	963-1414
					2 3/8			3 5/8	963-1415
					2 5/8			3 7/8	963-1416
					2 7/8			4 1/8	963-1417
					3 1/8			4 3/8	963-1418
					3 3/8			4 5/8	963-1419
					3 5/8			4 7/8	963-1420
					3 7/8			5 1/8	963-1421
					4 1/8			5 3/8	963-1422
					4 5/8			5 7/8	963-1424
					5 1/8			6 3/8	963-1426
					5 5/8			6 7/8	963-1428
					6 1/8			7 3/8	963-1430
2	3.170	3 9/16	3.375	1 1/4	1 5/8	2.035	2.457	2 7/8	963-1612
					2 1/8			3 3/8	963-1614
					2 3/8			3 5/8	963-1615
					2 5/8			3 7/8	963-1616
					2 7/8			4 1/8	963-1617
					3 1/8			4 3/8	963-1618
					3 3/8			4 5/8	963-1619
					3 5/8			4 7/8	963-1620
					3 7/8			5 1/8	963-1621
					4 1/8			5 3/8	963-1622
					4 5/8			5 7/8	963-1624
					5 1/8			6 3/8	963-1626
					5 5/8			6 7/8	963-1628
					6 1/8			7 3/8	963-1630
2 1/2	3.690	4 1/16	4.063	1 1/4	3 5/8	2.259	2.681	4 7/8	963-2020
					4 1/8			5 3/8	963-2022
					4 5/8			5 7/8	963-2024
					5 1/8			6 3/8	963-2026
					5 5/8			6 7/8	963-2028
					6 1/8			7 3/8	963-2030

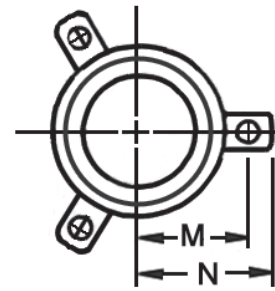
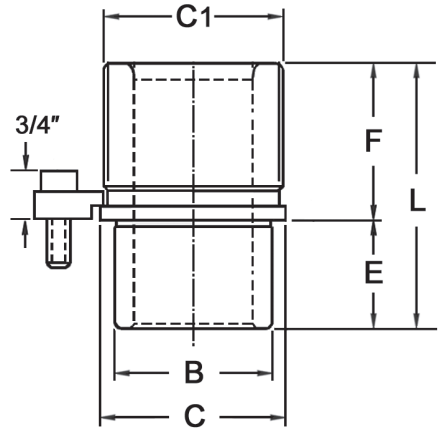

NOTE:
The 963 Series product line is not stocked, but is available as a special order.

TRANSITIONAL FIT STEEL SLEEVE BUSHINGS FOR BALL BEARING APPLICATIONS

LEMPCO Transitional Fit Steel Sleeve Bushings are manufactured from 52100 tool steel and precision machined. The I.D. is ground and honed to an 8-12 RMS finish to minimize resistance to free action of the retainer/Rotainer® bearings. See pages 13–15 for mounting instructions.

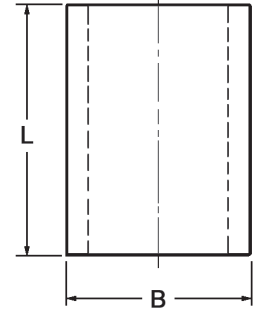

Nom. Post Diameter	B	L	Catalog Number
3/4	1.387	1 5/8	961-0607
		1 7/8	961-0608
		2 1/8	961-0609
		2 3/8	961-0610
		2 5/8	961-0611
		2 7/8	961-0612
		3 1/8	961-0613
		3 3/8	961-0614
		3 5/8	961-0615
		3 7/8	961-0616
		4 3/8	961-0618
		4 7/8	961-0620
		5 7/8	961-0624
		1	1.717
2 1/8	961-0809		
2 3/8	961-0810		
2 5/8	961-0811		
2 7/8	961-0812		
3 1/8	961-0813		
3 3/8	961-0814		
3 5/8	961-0815		
3 7/8	961-0816		
4 1/8	961-0817		
4 3/8	961-0818		
4 5/8	961-0819		
4 7/8	961-0820		
5 3/8	961-0822		
1 1/4	2.107	5 7/8	961-0824
		6 3/8	961-0826
		6 7/8	961-0828
		2 3/8	961-1010
		2 5/8	961-1011
		2 7/8	961-1012
		3 1/8	961-1013
		3 3/8	961-1014
		3 5/8	961-1015
		3 7/8	961-1016
		4 1/8	961-1017
		4 3/8	961-1018
		4 7/8	961-1020
		5 3/8	961-1022
5 7/8	961-1024		
6 1/8	961-1025		
6 3/8	961-1026		
6 7/8	961-1028		
7 7/8	961-1032		
8 7/8	961-1036		

Nom. Post Diameter	B	L	Catalog Number
1 1/2	2.437	2 7/8	961-1212
		3 1/8	961-1213
		3 3/8	961-1214
		3 5/8	961-1215
		3 7/8	961-1216
		4 1/8	961-1217
		4 3/8	961-1218
		4 5/8	961-1219
		4 7/8	961-1220
		5 1/8	961-1221
		5 3/8	961-1222
		5 7/8	961-1224
		6 3/8	961-1226
		6 7/8	961-1228
1 3/4	2.747	7 3/8	961-1230
		7 7/8	961-1232
		8 3/8	961-1234
		8 7/8	961-1236
		9 7/8	961-1240
		10 7/8	961-1244
		11 7/8	961-1248
		2 7/8	961-1412
		3 3/8	961-1414
		3 5/8	961-1415
		3 7/8	961-1416
		4 1/8	961-1417
		4 3/8	961-1418
		4 5/8	961-1419
4 7/8	961-1420		
5 1/8	961-1421		
5 3/8	961-1422		
5 7/8	961-1424		
6 3/8	961-1426		
6 7/8	961-1428		
7 3/8	961-1430		
7 7/8	961-1432		
8 3/8	961-1434		
8 7/8	961-1436		
9 7/8	961-1440		
10 7/8	961-1444		
11 7/8	961-1448		
12 7/8	961-1452		

Nom. Post Diameter	B	L	Catalog Number
2	3.162	2 7/8	961-1612
		3 3/8	961-1614
		3 5/8	961-1615
		3 7/8	961-1616
		4 1/8	961-1617
		4 3/8	961-1618
		4 5/8	961-1619
		4 7/8	961-1620
		5 1/8	961-1621
		5 3/8	961-1622
		5 7/8	961-1624
		6 3/8	961-1626
		6 7/8	961-1628
		7 3/8	961-1630
2 1/2	3.682	7 7/8	961-1632
		8 3/8	961-1634
		8 7/8	961-1636
		9 7/8	961-1640
		10 7/8	961-1644
		11 7/8	961-1648
		12 7/8	961-1652
		13 7/8	961-1656
		5 7/8	961-2024
		6 3/8	961-2026
		6 7/8	961-2028
		7 3/8	961-2030
		7 7/8	961-2032
		8 3/8	961-2034
8 7/8	961-2036		
9 3/8	961-2038		
9 7/8	961-2040		
10 7/8	961-2044		
11 7/8	961-2048		
12 7/8	961-2052		
13 7/8	961-2056		
3	4.182	5 7/8	961-2424
		6 3/8	961-2426
		6 7/8	961-2428
		7 3/8	961-2430
		7 7/8	961-2432
		8 3/8	961-2434
		8 7/8	961-2436
		9 7/8	961-2440
		10 7/8	961-2444
		11 7/8	961-2448
		12 7/8	961-2452
		13 7/8	961-2456

STRAIGHT GUIDE POSTS FOR BALL BEARING APPLICATIONS

LEMPCO Straight Guide Posts for ball bearing assemblies are manufactured from 52100 tool steel and precision ground. See pages 13–15 for mounting instructions.

Post Diameter A	Length L	Catalog Number
3/4 (.753)	2 7/8	951-0612
	3 1/8	951-0613
	3 3/8	951-0614
	3 5/8	951-0615
	3 7/8	951-0616
	4 1/8	951-0617
	4 3/8	951-0618
	4 5/8	951-0619
	4 7/8	951-0620
	5 3/8	951-0622
5 7/8	951-0624	
1 (1.003)	3 5/8	951-0815
	3 7/8	951-0816
	4 1/8	951-0817
	4 3/8	951-0818
	4 5/8	951-0819
	4 7/8	951-0820
	5 1/8	951-0821
	5 3/8	951-0822
	5 5/8	951-0823
	5 7/8	951-0824
	6 3/8	951-0826
	6 7/8	951-0828
	7 3/8	951-0830
	7 7/8	951-0832
	8 3/8	951-0834
	8 7/8	951-0836
	9 7/8	951-0840
	10 7/8	951-0844
11 7/8	951-0848	
1 1/4 (1.253)	4 3/8	951-1018
	4 5/8	951-1019
	4 7/8	951-1020
	5 1/8	951-1021
	5 3/8	951-1022
	5 5/8	951-1023
	5 7/8	951-1024
	6 3/8	951-1026
	6 7/8	951-1028
	7 3/8	951-1030
	7 7/8	951-1032
	8 3/8	951-1034
	8 7/8	951-1036
	9 7/8	951-1040
	10 7/8	951-1044
	11 7/8	951-1048

Post Diameter A	Length L	Catalog Number
1 1/2 (1.503)	4 3/8	951-1218
	4 5/8	951-1219
	4 7/8	951-1220
	5 1/8	951-1221
	5 3/8	951-1222
	5 5/8	951-1223
	5 7/8	951-1224
	6 3/8	951-1226
	6 7/8	951-1228
	7 3/8	951-1230
	7 7/8	951-1232
	8 3/8	951-1234
	8 7/8	951-1236
	9 3/8	951-1238
	9 7/8	951-1240
	10 3/8	951-1242
	10 7/8	951-1244
	11 3/8	951-1246
11 7/8	951-1248	
12 3/8	951-1250	
12 7/8	951-1252	
13 7/8	951-1256	
1 3/4 (1.753)	4 7/8	951-1420
	5 1/8	951-1421
	5 3/8	951-1422
	5 5/8	951-1423
	5 7/8	951-1424
	6 1/8	951-1425
	6 3/8	951-1426
	6 7/8	951-1428
	7 3/8	951-1430
	7 7/8	951-1432
	8 3/8	951-1434
	8 7/8	951-1436
	9 3/8	951-1438
	9 7/8	951-1440
	10 3/8	951-1442
	10 7/8	951-1444
11 3/8	951-1446	
11 7/8	951-1448	
12 3/8	951-1450	
12 7/8	951-1452	
13 7/8	951-1456	
14 7/8	951-1460	
16 7/8	951-1468	

Post Diameter A	Length L	Catalog Number
2 (2.003)	5 3/8	951-1622
	5 5/8	951-1623
	5 7/8	951-1624
	6 1/8	951-1625
	6 3/8	951-1626
	6 5/8	951-1627
	6 7/8	951-1628
	7 1/8	951-1629
	7 3/8	951-1630
	7 5/8	951-1631
	7 7/8	951-1632
	8 3/8	951-1634
	8 7/8	951-1636
	9 3/8	951-1638
	9 7/8	951-1640
	10 3/8	951-1642
	10 7/8	951-1644
11 3/8	951-1646	
11 7/8	951-1648	
12 3/8	951-1650	
12 7/8	951-1652	
13 7/8	951-1656	
14 7/8	951-1660	
15 7/8	951-1664	
16 7/8	951-1668	
17 7/8	951-1672	
2 1/2 (2.503)	7 7/8	951-2032
	8 3/8	951-2034
	8 7/8	951-2036
	9 7/8	951-2040
	10 7/8	951-2044
	11 7/8	951-2048
3 (3.003)	12 7/8	951-2052
	13 7/8	951-2056
	16 7/8	951-2068
	19 7/8	951-2080
	7 7/8	951-2432
	8 3/8	951-2434
	8 7/8	951-2436
	9 7/8	951-2440
	10 7/8	951-2444
	11 7/8	951-2448
	12 7/8	951-2452
13 7/8	951-2456	
16 7/8	951-2468	
19 7/8	951-2480	

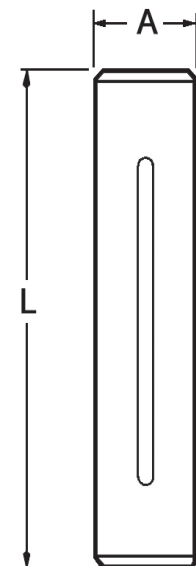

FLANGED DEMOUNTABLE GUIDE POSTS FOR BALL BEARING APPLICATIONS



LEMPCO Flanged Demountable Guide Posts for ball bearing assemblies are designed for those who prefer the convenience of a removable post to expedite die repairs. The post is tap fitted into the pin plate bore with the flange flush to the ground surface. See page 13 for bore size data.

These Demountable Guide Posts are manufactured from 52100 tool steel.

Required clamps and screws are included.

Post A	Diameter			Nominal Length					Catalog Number
	Flange B	C	E	F	Radius		Included Clamps & Screws	L	
					M	N			
1 (1.003)	1 5/16	1.0009 1.0006	1 3/16	2.428	13/16	1 1/8	3	3.6155	956-0815
				2.678				3.8655	956-0816
				2.928				4.1155	956-0817
				3.178				4.3655	956-0818
				3.428				4.6155	956-0819
				3.678				4.8655	956-0820
				3.928				5.1155	956-0821
				4.178				5.3655	956-0822
				4.428				5.6155	956-0823
				4.678				5.8655	956-0824
				5.178				6.3655	956-0826
				5.678				6.8655	956-0828
				6.178				7.3655	956-0830
				6.678				7.8655	956-0832
				7.178				8.3655	956-0834
7.678	8.8655	956-0836							
1 1/4 (1.253)	1 9/16	1.2509 1.2506	1 3/16	3.178	63/64	1 25/64	3	4.3655	956-1018
				3.428				4.6155	956-1019
				3.678				4.8655	956-1020
				3.928				5.1155	956-1021
				4.178				5.3655	956-1022
				4.428				5.6155	956-1023
				4.678				5.8655	956-1024
				5.178				6.3655	956-1026
				5.678				6.8655	956-1028
				6.178				7.3655	956-1030
				6.678				7.8655	956-1032
				7.178				8.3655	956-1034
				7.678				8.8655	956-1036
				8.678				9.8655	956-1040
				9.678				10.8655	956-1044
10.678	11.8655	956-1048							
1 1/2 (1.503)	1 7/8	1.5009 1.5006	1 7/16	2.928	1 1/8	1 17/32	3	4.3655	956-1218
				3.178				4.6155	956-1219
				3.428				4.8655	956-1220
				3.678				5.1155	956-1221
				3.928				5.3655	956-1222
				4.178				5.6155	956-1223
				4.428				5.8655	956-1224
				4.928				6.3655	956-1226
				5.428				6.8655	956-1228
				5.928				7.3655	956-1230
				6.428				7.8655	956-1232
				6.928				8.3655	956-1234
				7.428				8.8655	956-1236
				7.928				9.3655	956-1238
				8.428				9.8655	956-1240
8.928	10.3655	956-1242							
9.428	10.8655	956-1244							
9.928	11.3655	956-1246							
10.428	11.8655	956-1248							
10.928	12.3655	956-1250							
11.428	12.8655	956-1252							
12.428	13.8655	956-1256							
1 3/4 (7.753)	2 1/4	1.7509 1.7506	1 11/16	3.178	1 19/64	1 45/64	4	4.8655	956-1420
				3.428				5.1155	956-1421
				3.678				5.3655	956-1422
				3.928				5.6155	956-1423
				4.178				5.8655	956-1424
				4.428				6.1155	956-1425
				4.678				6.3655	956-1426
				5.178				6.8655	956-1428

FLANGED DEMOUNTABLE GUIDE POSTS FOR BALL BEARING APPLICATIONS

Diameter			Nominal Length						Catalog Number
Post A	Flange B	C	E	F	Radius		Included Clamps & Screws	L	
					M	N			
1 3/4 (7.753)	2 1/4	1.7509 1.7506	1 11/16	5.678	1 19/64	1 45/64	4	7.3655	956-1430
				6.178				7.8655	956-1432
				6.678				8.3655	956-1434
				7.178				8.8655	956-1436
				7.678				9.3655	956-1438
				8.178				9.8655	956-1440
				8.678				10.3655	956-1442
				9.178				10.8655	956-1444
				9.678				11.3655	956-1446
				10.178				11.8655	956-1448
				10.678				12.3655	956-1450
				11.178				12.8655	956-1452
				12.178				13.8655	956-1456
				13.178				14.8655	956-1460
				15.178				16.8655	956-1468
2 (2.003)	2 1/2	2.0009 2.0006	1 15/16	3.428	1 27/64	1 53/64	4	5.3655	956-1622
				3.678				5.6155	956-1623
				3.928				5.8655	956-1624
				4.178				6.1155	956-1625
				4.428				6.3655	956-1626
				4.678				6.6155	956-1627
				4.928				6.8655	956-1628
				5.178				7.1155	956-1629
				5.428				7.3655	956-1630
				5.678				7.6155	956-1631
				5.928				7.8655	956-1632
				6.428				8.3655	956-1634
				6.928				8.8655	956-1636
				7.428				9.3655	956-1638
				7.928				9.8655	956-1640
				8.428				10.3655	956-1642
				8.928				10.8655	956-1644
				9.428				11.3655	956-1646
				9.928				11.8655	956-1648
				10.428				12.3655	956-1650
10.928	12.8655	956-1652							
11.928	13.8655	956-1656							
12.928	14.8655	956-1660							
13.928	15.8655	956-1664							
14.928	16.8655	956-1668							
15.928	17.8655	956-1672							
2 1/2 (2.503)	3	2.5009 2.5006	1 15/16	5.928	1 43/64	2 5/64	4	7.8655	956-2032
				6.428				8.3655	956-2034
				6.928				8.8655	956-2036
				7.928				9.8655	956-2040
				8.928				10.8655	956-2044
				9.928				11.8655	956-2048
				10.928				12.8655	956-2052
				11.928				13.8655	956-2056
				14.928				16.8655	956-2068
				17.928				19.8655	956-2080
3 (3.003)	3 1/2	3.0009 3.0006	2 7/16	5.428	1 59/64	2 21/64	4	7.8655	956-2432
				5.928				8.3655	956-2434
				6.428				8.8655	956-2436
				7.428				9.8655	956-2440
				8.428				10.8655	956-2444
				9.428				11.8655	956-2448
				10.428				12.8655	956-2452
				11.428				13.8655	956-2456
				14.428				16.8655	956-2468
				17.428				19.8655	956-2480

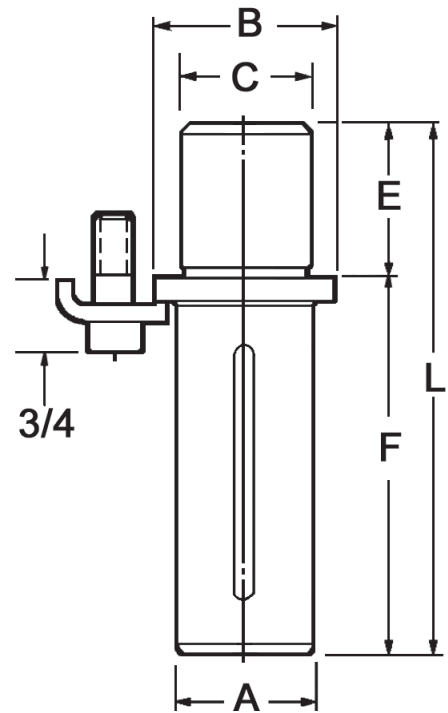

SHOULDER GUIDE POSTS FOR BALL BEARING APPLICATIONS

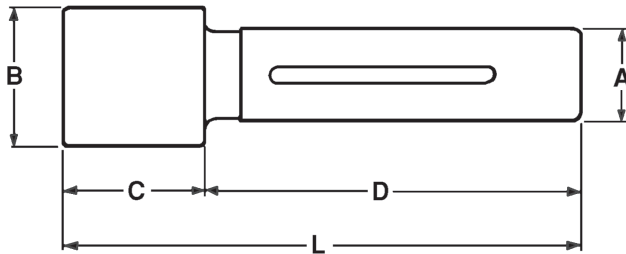

Mounting diameters of the LEMPCO Shoulder Guide Posts are a minimum of .008" over the sizes of Press Fit Steel Sleeve Bushings and .008" over the Demountable Steel Bushings to allow grind stock for precision fitting in new set construction and to allow reboring as necessary in replacing posts and bushings in used sets. These posts also may be used with Press Fit Sleeve Bushings and Demountable Bushings providing the through bore size accords with mounting diameters.

The Shoulder Guide Posts are manufactured from 52100 tool steel and precision ground. See pages 13–15 for mounting instructions.

Diameter A	B	Length L	C	D	Catalog Number	
1 (1.003)	1.725	1 3/8	1 3/8	4 3/8	3	953-0818
				4 7/8	3 1/2	953-0820
				5 3/8	4	953-0822
				5 7/8	4 1/2	953-0824
				6 3/8	5	953-0826
				6 7/8	5 1/2	953-0828
				7 3/8	6	953-0830
				7 7/8	6 1/2	953-0832
1 1/4 (1.253)	2.115	1 7/8	1 7/8	4 7/8	3	953-1020
				5 3/8	3 1/2	953-1022
				5 7/8	4	953-1024
				6 3/8	4 1/2	953-1026
				6 7/8	5	953-1028
				7 3/8	5 1/2	953-1030
				7 7/8	6	953-1032
				8 3/8	6 1/2	953-1034
				8 7/8	7	953-1036
				1 1/2 (1.503)	2.445	2 3/8
7 3/8	5	953-1230				
7 7/8	5 1/2	953-1232				
8 3/8	6	953-1234				
8 7/8	6 1/2	953-1236				
9 3/8	7	953-1238				
9 7/8	7 1/2	953-1240				
1 3/4 (1.753)	2.755	2 7/8	2 7/8			
				7 7/8	5	953-1432
				8 3/8	5 1/2	953-1434
				8 7/8	6	953-1436
				9 3/8	6 1/2	953-1438
				9 7/8	7	953-1440
2 (2.003)	3.170	3 3/8	3 3/8	7 7/8	4 1/2	953-1632
				8 7/8	5 1/2	953-1636
				9 7/8	6 1/2	953-1640
				10 7/8	7 1/2	953-1644
				11 7/8	8 1/2	953-1648
				12 7/8	9 1/2	953-1652
2 1/2 (2.503)	3.690	3 7/8	3 7/8	8 7/8	5	953-2036
				9 7/8	6	953-2040
				10 7/8	7	953-2044
				11 7/8	8	953-2048
				12 7/8	9	953-2052
				13 7/8	10	953-2056

NOTE:

The 953 Series product line is not stocked, but is available as a special order.

BALL BEARING ENGINEERING DATA

BORING PROCEDURES AND DIMENSIONS

Holes for LEMPCO Ball Bearing Guide

Posts and Bushings should be jig bored for best results. The punch holder and die holder should be clamped together and bored in one setup in order to maintain dead center alignment between the upper and lower bores. If it is not possible to bore in this manner, a tolerance of $\pm.0005"$ between centers (see illustration) must be held. Bores should be smooth and free from tool marks to provide proper bearing area for the guide post and bushing.

Die holder bores must be perpendicular to the surface of the die holder which will back up the die. The bottom surface of the die holder must be parallel to the die backup surface. The punch holder bores also must be perpendicular to the surface which will back up the punches, and the top surface parallel to the punch back-up surface.

Break the corners of the bored holes to a generous chamfer. On sets with a symmetrical profile one pin and bushing should be offset to prevent accidental reversing of the punch holder during assembly.

All of the LEMPCO Ball Bearing Guide Posts, Bushings Retainers and Rotainers® are completely interchangeable without the need for select fitting, and if mounted in accordance with boring and assembly instructions given on this and the following page do not require any grinding, honing, lapping, or any other modifications of any kind. Please note the dimensions given in the following table. Our experience over many years proves that these are optimum dimensions. Variations must be avoided.

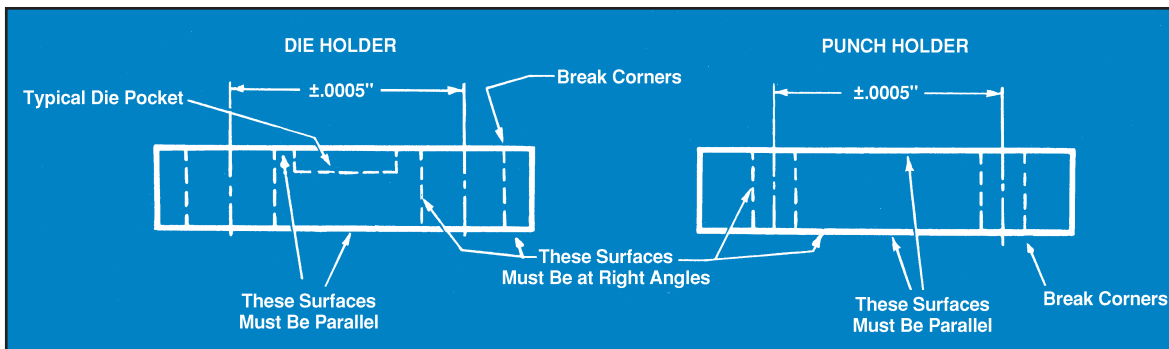

BORE CHART – BALL BEARING COMPONENTS (INCH)

Nominal Guide Post Diameter	#951-SERIES STRAIGHT GUIDE PIN (PRESS FIT)	#956-SERIES DEMOUNTABLE GUIDE PIN (TAP FIT)	#953-SERIES SHOULDER GUIDE PIN (PRESS FIT)	#961-SERIES STRAIGHT SLEEVE BUSHING (TRANSITIONAL FIT)	#962-SERIES DEMOUNTABLE SHOULDER BUSHING (TAP FIT)
	BORE SIZE	BORE SIZE	BORE SIZE	BORE SIZE	BORE SIZE
3/4	0.7515 / 0.7510	N/A	N/A	1.3872 / 1.3867	N/A
1	1.0015 / 1.0010	1.0016 / 1.0011	BORE HOLE .0009" TO .0019" SMALLER THAN SHOULDER DIAMETER OF GUIDE POST	1.7172 / 1.7167	1.7159 / 1.7154
1 1/4	1.2510 / 1.2505	1.2516 / 1.2511		2.1072 / 2.1067	2.1059 / 2.1054
1 1/2	1.5010 / 1.5005	1.5016 / 1.5011		2.4372 / 2.4367	2.4359 / 2.4354
1 3/4	1.7510 / 1.7505	1.7516 / 1.7511		2.7472 / 2.7467	2.7459 / 2.7454
2	2.0006 / 2.0001	2.0016 / 2.0011		3.1622 / 3.1617	3.1608 / 3.1603
2 1/2	2.5006 / 2.5001	2.5016 / 2.5011		3.6822 / 3.6817	3.6809 / 3.6804
3	3.0006 / 3.0001	3.0016 / 3.0011	N/A	4.1822 / 4.1817	4.1809 / 4.1804

BALL BEARING ENGINEERING DATA

INSTALLATION AND ASSEMBLY INSTRUCTIONS

In order to maintain the die and punch alignment, it is essential that the guide posts and bushings be at absolute right angles with the punch and die backup surfaces.

Figure 1 represents a typical guide post and ROTAINER®. Please note that the end of the guide post with the small radius is press fit into the punch shoe, and that the ROTAINER® is assembled with the ROTAINER® slide assembly toward the same end of the guide post.

NOTE: LEMPCO Demountable Bushings and Flanged Demountable Guide Posts are tap fitted. Bores should be to specifications, and both bushings and guide posts should be seated flush to ground surface of support shoe and held securely by clamps and cap screws. These bushings and guide posts are removable; on installation the die will register accurately.

Check the squareness of the guide post or bushing with a precision square. Tap the sides slightly with a soft hammer until the guide post or bushing is perpendicular.

Press fit about 1/4" (6.35mm) and check with the precision square again, tapping the sides with a soft hammer as necessary, to ensure squareness. A bronze, babbitt or fiber hammer is recommended.

NOTE: With Demountable Boss Bushings, be sure to press against the hardened liner and not against the casting.

Press fit by small increments – not over 1/2" (12.70mm) each – checking with the precision square after each press. Do not allow guide post or bushing to protrude through the lower side of the plate. It is advisable to place a 1/64" (.3968mm) shim under the guide post or bushing as a stop.

For Demountable Boss Bushings and Demountable Bushings, after the bushing is tap fit to the shoulder, the shoe may be drilled with the bushing in place. Tighten screws gradually, moving from one to another until all are tight.

After complete assembly of the bushings, check the ID top and bottom for taper. Should taper be found, hone the ID until original size is obtained.

NOTE: This should not be necessary if boring instructions were strictly adhered to.

Assemble ROTAINER® to guide post (**Figure 1**) by screwing the set screw in until flush with the special ROTAINER® slide. Vertical and the rotational movement should now be tested to insure freedom of movement. After testing is completed, stake set screw. Lubricate only with a light spindle oil.

NOTE: The only tool necessary to assemble the ROTAINER® is a screw driver.

Assemble the punch and die holder. Be sure to allow the ROTAINERS® to hang free (see **Figure 2**) supported by the special ROTAINER® slide when assembling the die set. Work the punch holder up and down a few times to assure there is no binding.



FIGURE 1

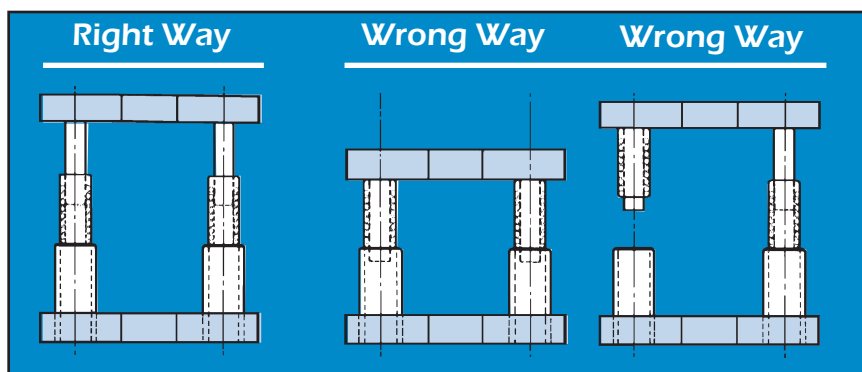

FIGURE 2

BALL BEARING ENGINEERING DATA

GENERAL DIE SET DESIGN PROCEDURES

SPECIFICATIONS:

1. Maximum Shut Height – See Figure 2, below.
2. Minimum Shut Height – See Figure 1.
3. Stroke – See Figures 2 and 3.
4. Maximum Open Height – See Figures 2 and 3.

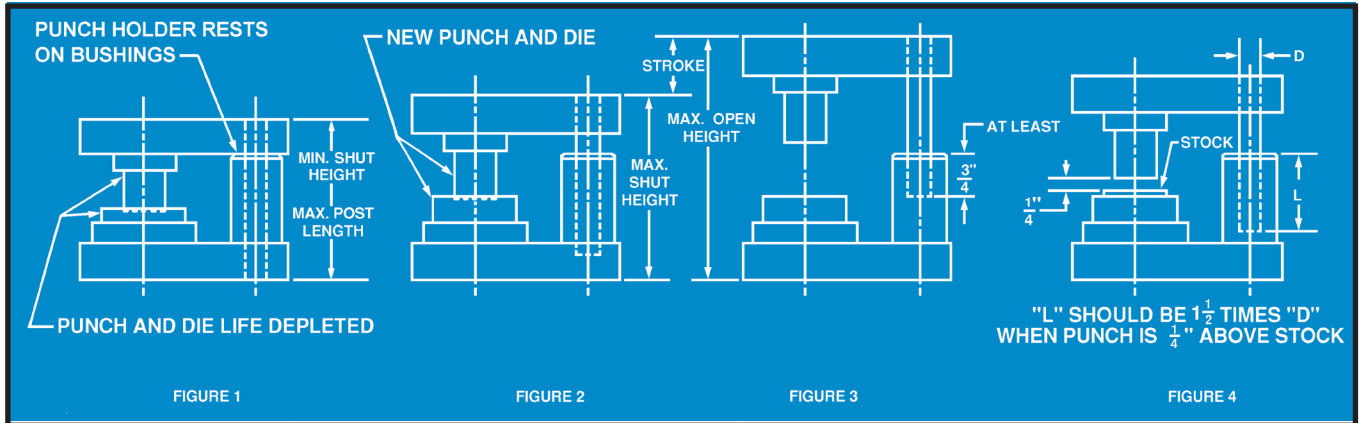

- A. Lay out die as in **Figure 1** (Minimum Shut Height). This determines maximum guide post length and maximum bushing height.
- B. Lay out die as in **Figure 2** (Maximum Shut Height).
- C. Maximum Open Height (Maximum Shut Height plus Stroke) as in **Figure 3** shows minimum guide post engagement in bushing that is required. If this is at least $\frac{3}{4}$ " then conditions are ideal. However, if this dimension is less than $\frac{3}{4}$ " then **Figure 4** should be considered. Actual work is done for only a fraction of the total stroke on most dies and if conditions shown in **Figure 4** are satisfied in conjunction with **Figure 1** and **Figure 2**, then full length of stroke and maximum open height can be disregarded.

ALSO NOTE, HOWEVER, THAT LONGER THAN NORMAL STROKES MAY BE UTILIZED BY DISENGAGING GUIDE POST AND, IF ABSOLUTELY NECESSARY, THE ROTAINER® FROM THE BUSHING ON THE UPWARD TRAVEL PROVIDED:

- 1 – THE OPERATION IS VERTICAL
- 2 – THE OPERATION IS NOT FASTER THAN 150 STROKES PER MINUTE, AND
- 3 – THE INSIDE DIAMETER OF THE BUSHING IS BELL MOUTHED MINIMUM $\frac{1}{4}$ ".

ON INCLINED OPERATIONS, OR AT SPEEDS IN EXCESS OF 150 STROKES PER MINUTE, THE GUIDE POST MUST ENGAGE THE BUSHING AT ALL TIMES AT LEAST $\frac{3}{4}$ " (THE ROTAINER® MUST BE ENGAGED BY THE GUIDE POST AND BUSHINGS AT ALL TIMES).

OPERATING CONDITIONS

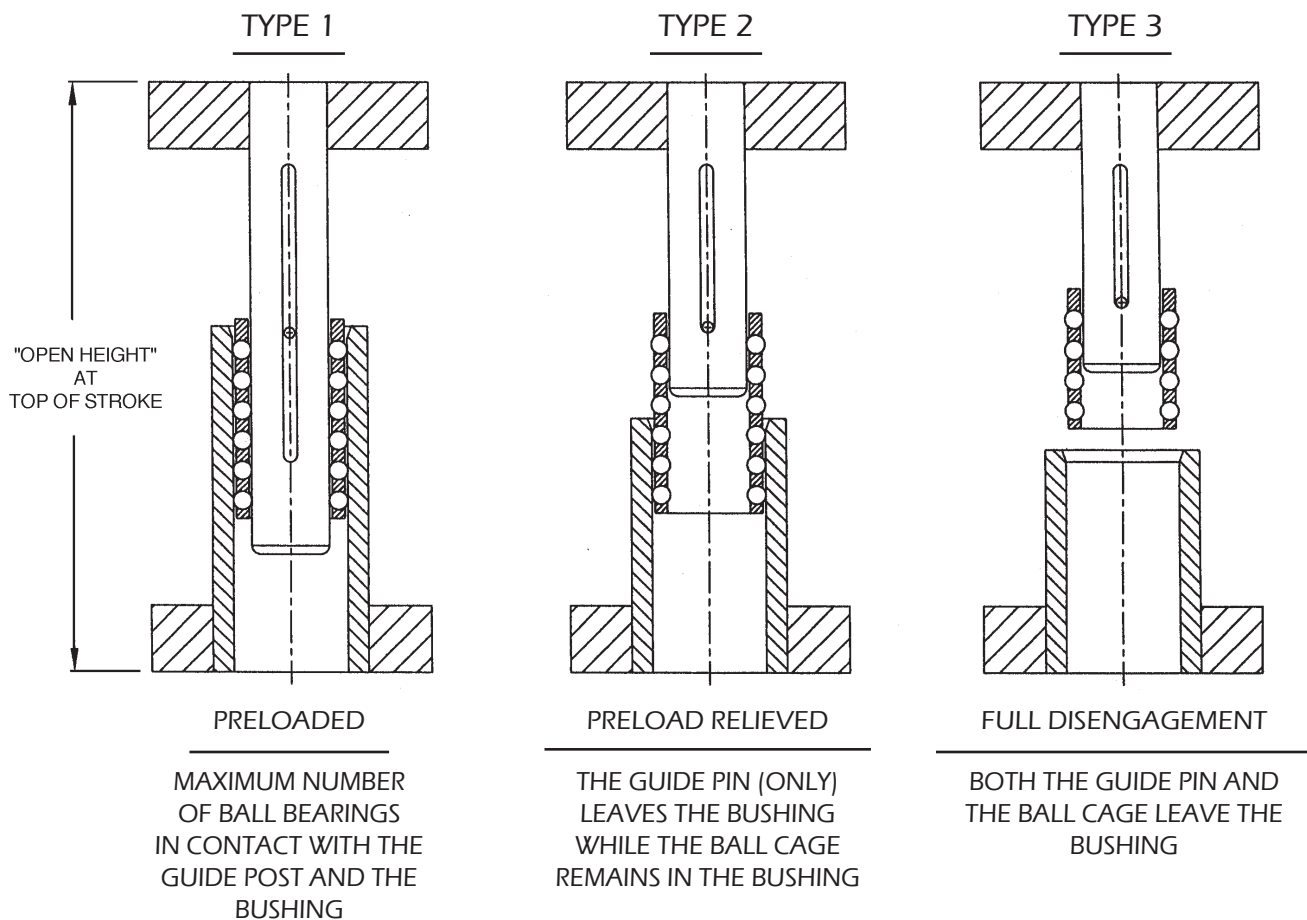

BALL-BEARING COMPONENT MAINTENANCE



Always use Ball-Lube® and Ball-Scrubb® to keep ball-bearing components clean and running smooth.

Component maintenance is a serious business...

BALL-SCRUBB® removes heavy soils, dirt or grease from ball-bearing guide pin assemblies.

Just spray it on...wait 3 minutes... and spray again. Then blow off excess with compressed air.

BALL-SCRUBB® is an industrial strength cleaner with rust inhibitors, specially formulated to clean debris and grease from all types of ball-bearing assemblies.

BALL-LUBE®, when applied after BALL-SCRUBB®, locks out wear by chemically bonding to precision surfaces. It provides a tough, long-lasting shield that protects against oxidation and rust.

BALL-LUBE® lubricates assemblies and gives them longtime protection against wear, oxidation and heat.

Spray liberally on ball-bearing assemblies.

TECHNICAL BULLETIN FOR BALL BEARING RETAINERS

Figure 1:
Two-Point Stake



Figure 2:
Orbital Stake

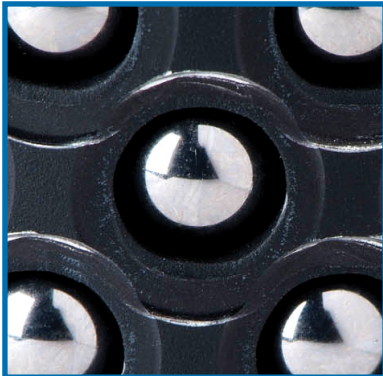

Figure 3:
Stake Stress – Two-Point

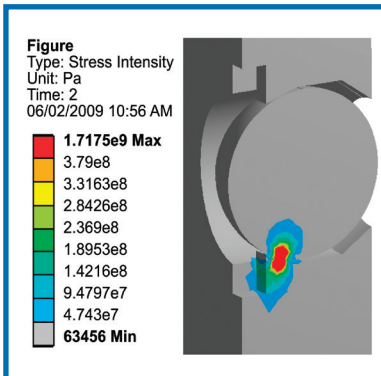
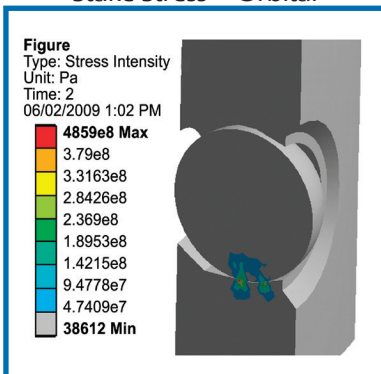

Figure 4:
Stake Stress – Orbital



BACKGROUND

Fatigue failures begin with a small crack in the material. The crack will develop at a point of discontinuity in the material, such as a change in cross section, a keyway, or a hole. Once a crack has developed, the stress-concentration effect becomes greater and the crack progresses more rapidly. As the stressed area decreases in size, the stress increases in magnitude until, finally, the remaining area fails suddenly.

The original LEMPCO ball staking design consisted of small rectangular indentations opposing each other at 180° degrees around the ball (two-point staking); see **Figure 1**. This staking design consists of no/minimal radii, two full corners, and numerous material discontinuities, all allowing opportunities for crack propagation.

SOLUTION

We developed an improved ball staking method that consists of a complete circular indentation around the entire ball (orbital staking); see **Figure 2**. This design utilizes a uniform circular metal forming technique, with no sharp discontinuities in the material. The new method is intended to improve performance in regards to operational life cycle.

CONCLUSION

After an independent third party* ran a Finite Element Analysis, the following can be concluded:

The peak stress and stress levels in general are much higher for the two-point stake than for the orbital stake. Figure 3 shows stress contours for the two-point stake, Figure 4 shows stress contours for the orbital stake.

Due to the smaller volume of material in the two-point stake, high stresses exist in a significant portion of the indented material.

The differences in stress levels and distribution imply that the fatigue life for the two-point stake will be much less than for the orbital stake, and with the lower stresses the orbital stake should improve the fatigue life.

The differences in stress levels of the orbital stake design also imply that press speed can be increased with the orbital stake compared to the two-point stake.

* O'Donnell Consulting Engineers, Inc. <http://www.odonnellconsulting.com/fea.html>

LEMPCOLOY® PLAIN BEARING BUSHINGS

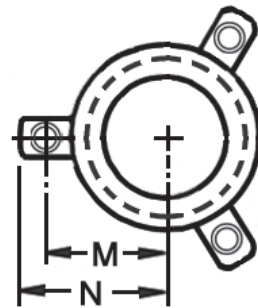
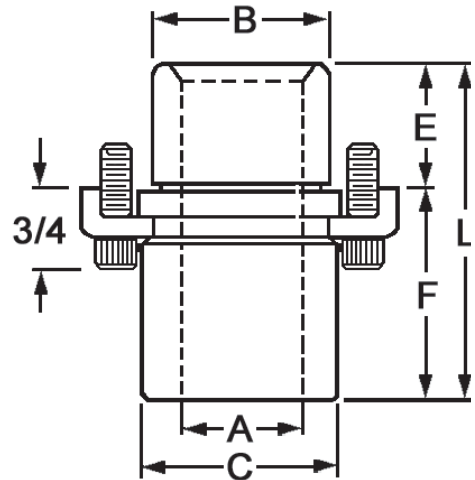

These unique hard coated aluminum bushings have the surface hardness of case hardened steel. An electrochemical process is used to increase the corrosion resistance of the bushings. As a result of this Hard Anodized process, they are also non-conductive, so they may be used for electrical discharge machining. They have a hard surface that is highly resistant to wear and not subject to magnetization. These bushings are for clean room and EDM applications and should not be used in any stamping operation wherein a lot of contaminants are generated.

Lempcoloy® bushings do not require lubrication and therefore are not provided with the conventional figure-eight oil grooves and fittings. While these bushings do not require lubrication, we recommend you apply a light mist of spindle oil prior to assembly and spray lightly prior to each press run.

Lempcoloy® bushings are designed to be installed by tap fitting to seat flush with the ground surface of the punch holder. They are assembled with toe clamps and screws. These bushings must not be pressed in or honed. These Lempcoloy® bushings will work well when used with Lamina plain bearing guide posts.

LEMPCOLOY® PLAIN BEARING BUSHINGS

Shoulder - Lempcoloy®

Catalog Number	Inside Dia. A Nom.	B	C	E	F	L	Radius	
							M	N
608-0409-LAM	1/2	0.812	15/16	5/8	1 1/2	2 1/8	0.697	1.010
608-0509-LAM	5/8	1.000	1 3/16	5/8	1 1/2	2 1/8	0.813	1.125
608-0611-LAM	3/4	1.125	1 5/16	7/8	1 3/4	2 5/8	0.875	1.188
608-0811-LAM	1	1.500	1 11/16	7/8	1 3/4	2 5/8	1.063	1.375
608-1013-LAM	1 1/4	1.750	1 15/16	1 1/8	2	3 1/8	1.219	1.531
608-1214-LAM	1 1/2	2.000	2 3/16	1 3/8	2	3 3/8	1.344	1.656
608-1414-LAM	1 3/4	2.250	2 1/2	1 3/8	2	3 3/8	1.500	1.813
608-1616-LAM	2	2.500	2 7/8	1 13/16	2	3 13/16	1.703	2.016
608-2018-LAM	2 1/2	3.250	3 5/8	1 13/16	2 1/2	4 5/16	2.078	2.391
608-2418-LAM	3	3.750	4 1/8	1 13/16	2 1/2	4 5/16	2.344	2.656

Short Shoulder - Lempcoloy®

Catalog Number	Inside Dia. A Nom.	B	C	E	F	L	Radius	
							M	N
607-0406-LAM	1/2	0.812	15/16	5/8	13/16	1 7/16	0.697	1.010
607-0506-LAM	5/8	1.000	1 3/16	5/8	13/16	1 7/16	0.813	1.125
607-0607-LAM	3/4	1.125	1 5/16	7/8	13/16	1 11/16	0.875	1.188
607-0807-LAM	1	1.500	1 11/16	7/8	13/16	1 11/16	1.063	1.375
607-1008-LAM	1 1/4	1.750	1 15/16	1 1/8	13/16	1 15/16	1.219	1.531
607-1209-LAM	1 1/2	2.000	2 3/16	1 3/8	13/16	2 3/16	1.344	1.656
607-1410-LAM	1 3/4	2.250	2 1/2	1 3/8	1	2 3/8	1.500	1.813
607-1612-LAM	2	2.500	2 7/8	1 13/16	1	2 13/16	1.703	2.016
607-2012-LAM	2 1/2	3.250	3 5/8	1 13/16	1	2 13/16	2.078	2.391
607-2412-LAM	3	3.750	4 1/8	1 13/16	1	2 13/16	2.344	2.656

Clamps for Assembly

Catalog Number	Inside Dia. A Nom.	Number of Clamps
899-9025	1	2
899-9125	1 1/4	3
899-9125	1 1/2	3
899-9125	1 3/4	4
899-9125	2	4
899-9125	2 1/2	4
899-9125	3	4

NOTE:

For bushings with .002 over nominal ID to be used with a discontinued LEMPCO plain bearing guide post, remove the "-LAM" suffix from the part number.

ROTAINERS®

FOR METRIC BALL BEARING APPLICATIONS

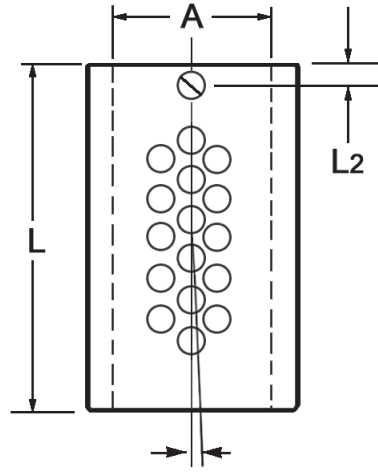

Radial bearing placement reduces wear and tracking.

Designed to rotate on the post, as well as maintain its vertical motion, LEMPCO ROTAINERS® were developed to greatly reduce the amount of tracking. The disengagement of the guide post from the bushing by 6.35mm at the top of the stroke will allow the ROTAINER® to rotate 360° on the guide post. The ROTAINER®, while still designed to track, (assuring a measurable amount of preload) will enable stampers to achieve high press production by reducing expensive replacement costs.

Nom. Post Diameter (mm) A	Length (mm) L	Set Screw (mm) L2	Catalog Number (mm)
19	39	7.59	367-19390
	51		367-19510
	65		367-19650
25	39	7.59	367-25390
	51		367-25510
	65		367-25650
32	62	10.64	367-32580
	75		367-32700
	87		367-32830
40	68	10.64	367-40650
	81		367-40770
	100		367-40960
44	75	10.80	367-44700
	87		367-44830
	113		367-44108
50	89	10.64	367-50830
	108		367-50102
	121		367-50114
63	100	10.64	367-63100
	140		367-63140
	178		367-63178
80	100	10.64	367-80100
	140		367-80140
	178		367-80178

NOTES:

Diameters and lengths not listed are available by special order. The LAST length for each diameter shown in the table above should be used for general die set applications. Other lengths are for limited space and special applications. Under a preloaded condition, the ROTAINER® will only move vertically.

Rotainer® Slide Replacement With Screw Assembly		Number of Inserts
Nom. (mm)	Assembly Part Number	
19	06CLIP	1
25	08CLIP	1
32	10CLIP	1
40	12CLIP	1
44	14CLIP	1
50	16CLIP	2
63	20CLIP	2
80	24CLIP	2

PRECISION BALL BEARING RETAINERS FOR METRIC BALL BEARING APPLICATIONS

Nom. Post Diameter (mm) A	Length (mm) L	Set Screw (mm) L2	Catalog Number (mm)
19	39	6.35	937-19390
	51		937-19510
	65		937-19650
25	39		937-25390
	51		937-25510
	65		937-25650
32	58		937-32580
	70		937-32700
	83		937-32830
40	65		937-40650
	77		937-40770
	96		937-40960
44	70		937-44700
	83		937-44830
	108		937-44108
50	83	937-50830	
	102	937-50102	
	114	937-50114	
63	100	12.70	937-63100
	140		937-63140
	178		937-63178
80	100	7.94	937-80100
	140		937-80140
	178		937-80178

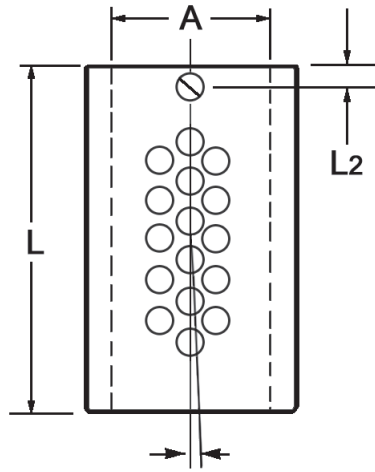

Radial bearing placement reduces wear and tracking.



LEMPCO Precision Ball Bearing Retainers possess resistance to normal wear and to lateral motion, are smooth in high speed operation and offer precise die register. They are keyed to the guide post slot with a set screw.

NOTE:

The LAST length for each diameter shown in the table above should be used for general die set applications. Other lengths are for limited space and special applications.

Set Screw Replacements		Number of Set Screws
Nom. (mm)	Set Screw Part Number	
19	SETSCREW 101214	1
25	SETSCREW 101214	1
32	SETSCREW 162024	1
40	SETSCREW 162024	1
44	SETSCREW 162024	1
50	SETSCREW 162024	2
63	SETSCREW 162024	2
80	SETSCREW 162024	2

DEMOUNTABLE STEEL GUIDE POST BUSHINGS FOR METRIC BALL BEARING APPLICATIONS



LEMPCO Demountable Guide Post Bushings are manufactured from 52100 tool steel and precision machined. See pages 14 & 28 for mounting instructions.

Diameters and lengths not listed are available by special order.

Required clamps and screws are included.

Nom. Post Diameter	B	C	C1	E	F	Radius		L	Catalog Number
						M	N		
25	43.956	51	50.80	30	25	31	40.5	55	966-25055
					30			60	966-25060
					35			65	966-25065
					40			70	966-25070
					45			75	966-25075
					50			80	966-25080
					55			85	966-25085
					60			90	966-25090
					65			95	966-25095
32	53.959	61	59.94	30	35	36.627	47.346	65	966-32065
					40			70	966-32070
					45			75	966-32075
					50			80	966-32080
					55			85	966-32085
					60			90	966-32090
					65			95	966-32095
					75			105	966-32105
					80			110	966-32110
					85			115	966-32115
					100			130	966-32130
					110			140	966-32140
					125			155	966-32155
40	64.960	72	63.50	35	40	42.190	52.908	75	966-40075
					45			80	966-40080
					50			85	966-40085
					55			90	966-40090
					60			95	966-40095
					65			100	966-40100
					75			110	966-40110
					80			115	966-40115
					85			120	966-40120
					90			125	966-40125
					100			135	966-40135
					105			140	966-40140
					120			155	966-40155

DEMOUNTABLE STEEL GUIDE POST BUSHINGS

FOR METRIC BALL BEARING APPLICATIONS

Nom. Post Diameter	B	C	C1	E	F	Radius		L	Catalog Number
						M	N		
44	73.959	81	73.03	35	40	46.939	57.658	75	966-44075
					55			90	966-44090
					60			95	966-44095
					65			100	966-44100
					75			110	966-44110
					80			115	966-44115
					90			125	966-44125
					100			135	966-44135
					105			140	966-44140
					120			155	966-44155
					130			165	966-44165
					145			180	966-44180
					155			190	966-44190
					50			80.959	91
55	90	966-50090							
60	95	966-50095							
65	100	966-50100							
75	110	966-50110							
80	115	966-50115							
90	125	966-50125							
100	135	966-50135							
105	140	966-50140							
120	155	966-50155							
130	165	966-50165							
145	180	966-50180							
155	190	966-50190							
63	94.960	105	101.85	35		90	58.852		
					105	140		966-63140	
					120	155		966-63155	
					130	165		966-63165	
					145	180		966-63180	
					155	190		966-63190	
80	111.960	122	114.30	35	90	67.590	78.283	125	966-80125
					105			140	966-80140
					120			155	966-80155
					130			165	966-80165
					145			180	966-80180
					155			190	966-80190

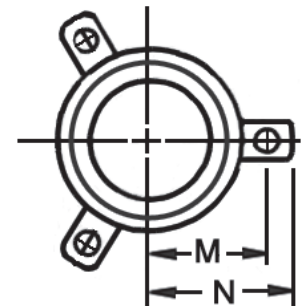
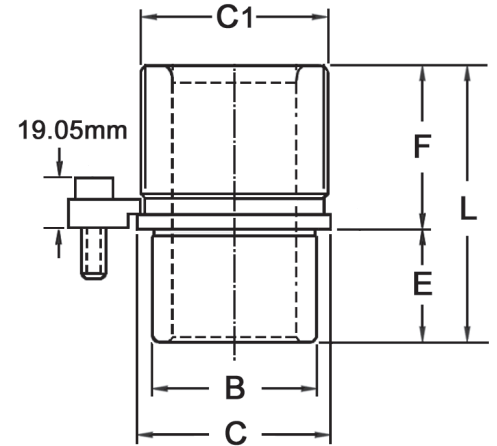

NOTES:

The 966 Series product line is not stocked, but is available as a special order.
 The "C" dimension measurement is from the outside edge of the flange to the opposite outside edge.

TRANSITIONAL FIT STEEL SLEEVE BUSHINGS FOR METRIC BALL BEARING APPLICATIONS

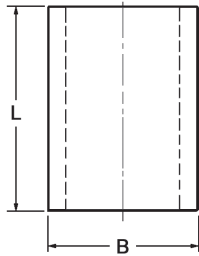

LEMPCO Transitional Fit Steel Sleeve Bushings are manufactured from 52100 tool steel and precision machined. The I.D. is ground and honed to an 8-12 RMS finish to minimize resistance to free action of the retainer/Rotainer® bearings.

Nom. Post Diameter	B	L	Catalog Number
19	36.000	47.0	967-19500
		51.8	967-19550
		62.0	967-19650
		66.8	967-19700
		71.9	967-19750
		77.0	967-19800
		86.9	967-19900
		91.9	967-19950
		96.8	967-19100
		106.9	967-19110
		121.9	967-19125
		146.8	967-19150
25	44.000	71.9	967-25750
		77.0	967-25800
		86.9	967-25900
		91.9	967-25950
		96.8	967-25100
		101.9	967-25105
		112.0	967-25115
		116.8	967-25120
		121.9	967-25125
		136.9	967-25140
		146.8	967-25150
		161.8	967-25165
172.0	967-25175		

Nom. Post Diameter	B	L	Catalog Number
32	54.000	71.9	967-32750
		77.0	967-32800
		86.9	967-32900
		91.9	967-32950
		96.8	967-32100
		101.9	967-32105
		112.0	967-32115
		121.9	967-32125
		136.9	967-32140
		146.8	967-32150
		161.8	967-32165
		172.0	967-32175
196.9	967-32200		
226.8	967-32230		
40	65.000	96.8	967-40100
		101.9	967-40105
		112.0	967-40115
		116.8	967-40120
		121.9	967-40125
		131.8	967-40135
		136.9	967-40140
		146.8	967-40150
		161.8	967-40165
		172.0	967-40175
		186.9	967-40190
		196.9	967-40200
211.8	967-40215		
226.8	967-40230		
246.9	967-40250		
276.9	967-40280		
296.9	967-40300		
44	74.000	121.9	967-44125
		131.8	967-44135
		136.9	967-44140
		146.8	967-44150
		161.8	967-44165
		172.0	967-44175
		186.9	967-44190
		196.9	967-44200
		211.8	967-44215
		226.8	967-44230
		246.9	967-44250
		276.9	967-44280
296.9	967-44300		
326.9	967-44330		

Nom. Post Diameter	B	L	Catalog Number
50	81.000	121.9	967-50125
		131.8	967-50135
		136.9	967-50140
		146.8	967-50150
		161.8	967-50165
		172.0	967-50175
		186.9	967-50190
		196.9	967-50200
		211.8	967-50215
		226.8	967-50230
		246.9	967-50250
		276.9	967-50280
296.9	967-50300		
326.9	967-50330		
347.0	967-50350		
63	95.000	146.8	967-63150
		161.8	967-63165
		172.0	967-63175
		186.9	967-63190
		196.9	967-63200
		211.8	967-63215
		226.8	967-63230
		246.9	967-63250
		276.9	967-63280
		296.9	967-63300
		326.9	967-63330
		347.0	967-63350
80	112.000	146.8	967-80150
		161.8	967-80165
		172.0	967-80175
		186.9	967-80190
		196.9	967-80200
		211.8	967-80215
		226.8	967-80230
		246.9	967-80250
		276.9	967-80280
		296.9	967-80300
		326.9	967-80330
		347.0	967-80350

STRAIGHT GUIDE POSTS FOR METRIC BALL BEARING APPLICATIONS

LEMPCO Straight Guide Posts for ball bearing assemblies are manufactured from 52100 tool steel and precision ground. See pages 14 & 28 for mounting instructions.

Post Diameter A	Length L	Catalog Number
19	71.9	957-19750
	86.9	957-19900
	97.0	957-19100
	106.9	957-19110
	112.0	957-19115
	116.8	957-19120
	121.9	957-19125
146.8	957-19150	
25	97.0	957-25100
	106.9	957-25110
	112.0	957-25115
	116.8	957-25120
	121.9	957-25125
	131.8	957-25135
	136.9	957-25140
	142.0	957-25145
	146.8	957-25150
	161.8	957-25165
	172.0	957-25175
	186.9	957-25190
	196.9	957-25200
211.8	957-25215	
226.8	957-25230	
32	121.9	957-32125
	131.8	957-32135
	136.9	957-32140
	142.0	957-32145
	146.8	957-32150
	161.8	957-32165
	172.0	957-32175
	186.9	957-32190
	196.9	957-32200
	211.8	957-32215
	226.8	957-32230
	246.9	957-32250
	256.8	957-32260
276.9	957-32280	
296.9	957-32300	

Post Diameter A	Length L	Catalog Number
40	121.9	957-40125
	131.8	957-40135
	136.9	957-40140
	142.0	957-40145
	146.8	957-40150
	161.8	957-40165
	172.0	957-40175
	186.9	957-40190
	196.9	957-40200
	211.8	957-40215
	226.8	957-40230
	237.0	957-40240
	246.9	957-40250
	261.9	957-40265
	276.9	957-40280
	287.0	957-40290
	296.9	957-40300
	311.9	957-40315
	326.9	957-40330
356.9	957-40360	
44	121.9	957-44125
	131.8	957-44135
	136.9	957-44140
	142.0	957-44145
	146.8	957-44150
	161.8	957-44165
	172.0	957-44175
	186.9	957-44190
	196.9	957-44200
	211.8	957-44215
	226.8	957-44230
	237.0	957-44240
	246.9	957-44250
	261.9	957-44265
	276.9	957-44280
	287.0	957-44290
	296.9	957-44300
	311.9	957-44315
	326.9	957-44330
356.9	957-44360	

Post Diameter A	Length L	Catalog Number
50	146.8	957-50150
	161.8	957-50165
	172.0	957-50175
	186.9	957-50190
	196.9	957-50200
	211.8	957-50215
	226.8	957-50230
	237.0	957-50240
	246.9	957-50250
	261.9	957-50265
	276.9	957-50280
	287.0	957-50290
	296.9	957-50300
	311.9	957-50315
	326.9	957-50330
	356.9	957-50360
	376.9	957-50380
	397.0	957-50400
	427.0	957-50430
456.9	957-50460	
63	196.9	957-63200
	211.8	957-63215
	226.8	957-63230
	237.0	957-63240
	246.9	957-63250
	261.9	957-63265
	276.9	957-63280
	296.9	957-63300
	311.9	957-63315
	326.9	957-63330
356.9	957-63360	
376.9	957-63380	
427.0	957-63430	
496.8	957-63500	
80	196.9	957-80200
	211.8	957-80215
	226.8	957-80230
	246.9	957-80250
	276.9	957-80280
	296.9	957-80300
	326.9	957-80330
	356.9	957-80360
	427.0	957-80430
	496.8	957-80500

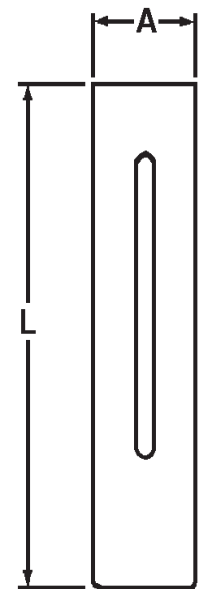

FLANGED DEMOUNTABLE GUIDE POSTS FOR METRIC BALL BEARING APPLICATIONS



Post	Diameter		Nominal Length			Catalog Number
	A	B	C	E	F	
24.953 24.940	33	24.953 24.940	30	60	90	958-25090
				70	100	958-25100
				80	110	958-25110
				85	115	958-25115
				90	120	958-25120
				95	125	958-25125
				105	135	958-25135
				110	140	958-25140
				115	145	958-25145
				120	150	958-25150
				135	165	958-25165
				145	175	958-25175
				160	190	958-25190
				170	200	958-25200
185	215	958-25215				
200	230	958-25230				
31.953 31.940	40	31.953 31.940	30	85	115	958-32115
				90	120	958-32120
				95	125	958-32125
				105	135	958-32135
				110	140	958-32140
				115	145	958-32145
				120	150	958-32150
				135	165	958-32165
				145	175	958-32175
				160	190	958-32190
				170	200	958-32200
				185	215	958-32215
				200	230	958-32230
				220	250	958-32250
250	280	958-32280				
270	300	958-32300				
39.952 39.939	48	39.952 39.939	36	79	115	958-40115
				84	120	958-40120
				89	125	958-40125
				99	135	958-40135
				104	140	958-40140
				109	145	958-40145
				114	150	958-40150
				129	165	958-40165
				139	175	958-40175
				154	190	958-40190
				164	200	958-40200
				179	215	958-40215
				194	230	958-40230
				204	240	958-40240
				214	250	958-40250
				224	260	958-40260
				244	280	958-40280
				254	290	958-40290
				264	300	958-40300
				279	315	958-40315
294	330	958-40330				
324	360	958-40360				
43.952 43.939	57	43.952 43.939	43	82	125	958-44125
				92	135	958-44135
				97	140	958-44140
				102	145	958-44145
				107	150	958-44150
				112	155	958-44155
				122	165	958-44165

LEMPCO Flanged Demountable Guide Posts for ball bearing assemblies are designed for those who prefer the convenience of a removable post to expedite die repairs. The post is tap fitted into the pin plate bore with the flange flush to the ground surface. See pages 14 & 28 for mounting instructions.

These Demountable Guide Posts are manufactured from 52100 tool steel.

Required clamps and screws are included.

FLANGED DEMOUNTABLE GUIDE POSTS FOR METRIC BALL BEARING APPLICATIONS

Post	Diameter		Nominal Length			Catalog Number
	A	B	C	E	F	
43.952 43.939	57	43.952 43.939	43	132	175	958-44175
				147	190	958-44190
				157	200	958-44200
				172	215	958-44215
				187	230	958-44230
				197	240	958-44240
				207	250	958-44250
				217	260	958-44260
				237	280	958-44280
				247	290	958-44290
				257	300	958-44300
				272	315	958-44315
				287	330	958-44330
				317	360	958-44360
				337	380	958-44380
387	430	958-44430				
49.952 49.939	63	49.952 49.939	49	91	140	958-50140
				96	145	958-50145
				101	150	958-50150
				106	155	958-50155
				116	165	958-50165
				121	170	958-50170
				126	175	958-50175
				131	180	958-50180
				141	190	958-50190
				146	195	958-50195
				151	200	958-50200
				166	215	958-50215
				181	230	958-50230
				191	240	958-50240
				201	250	958-50250
				211	260	958-50260
				231	280	958-50280
				241	290	958-50290
				251	300	958-50300
				266	315	958-50315
281	330	958-50330				
311	360	958-50360				
331	380	958-50380				
351	400	958-50400				
381	430	958-50430				
411	460	958-50460				
62.952 62.939	76	62.952 62.939	49	151	200	958-63200
				166	215	958-63215
				181	230	958-63230
				201	250	958-63250
				231	280	958-63280
				251	300	958-63300
				281	330	958-63330
				311	360	958-63360
381	430	958-63430				
451	500	958-63500				
79.952 79.939	93	79.952 79.939	62	138	200	958-80200
				153	215	958-80215
				168	230	958-80230
				188	250	958-80250
				218	280	958-80280
				238	300	958-80300
				268	330	958-80330
				298	360	958-80360
				368	430	958-80430
				438	500	958-80500

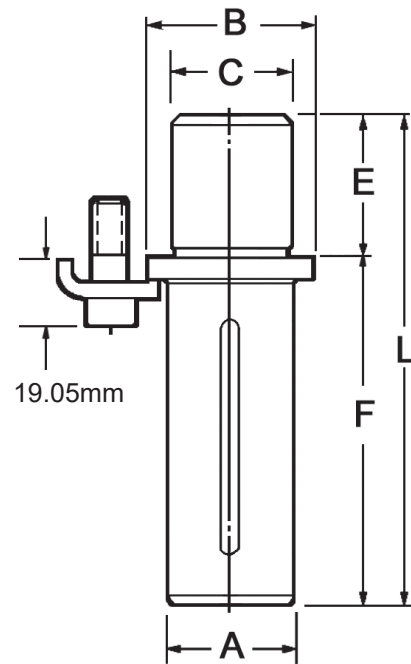

BALL BEARING ENGINEERING DATA - METRIC

BORING PROCEDURES AND DIMENSIONS

Holes for LEMPCO Ball Bearing Guide Posts and Bushings should be jig bored for best results. The punch holder and die holder should be clamped together and bored in one setup in order to maintain dead center alignment between the upper and lower bores. If it is not possible to bore in this manner, a tolerance of $\pm 0.0127\text{mm}$ between centers (see illustration) must be held. Bores should be smooth and free from tool marks to provide proper bearing area for the guide post and bushing.

Die holder bores must be perpendicular to the surface of the die holder which will back up the die. The bottom surface of the die holder must be parallel to the die backup surface. The punch holder bores also must be perpendicular to the surface which will back up the punches, and the top surface parallel to the punch backup surface.

Break the corners of the bored holes to a generous chamfer. On sets with a symmetrical profile one pin and bushing should be offset to prevent accidental reversing of the punch holder during assembly.

All of the LEMPCO Ball Bearing Guide Posts, Bushings, Retainers and Rotainers® are completely interchangeable without the need for select fitting, and if mounted in accordance with boring and assembly instructions given on this and on page 14 do not require any grinding, honing, lapping, or any other modifications of any kind. Please note the dimensions given in the following table. Our experience over many years proves that these are optimum dimensions. Variations must be avoided.

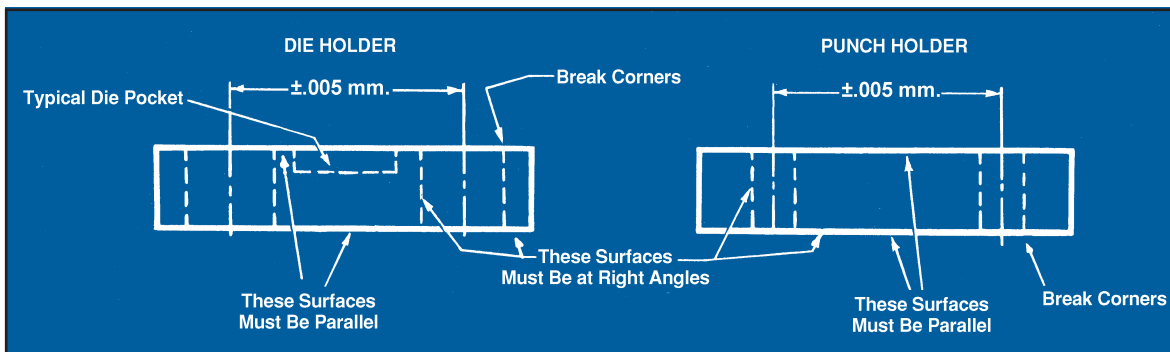

BORE CHART – BALL BEARING COMPONENTS (METRIC)

Nominal Guide Post Diameter	#957-SERIES STRAIGHT GUIDE PIN (PRESS FIT)	#958-SERIES DEMOUNTABLE GUIDE PIN (TAP FIT)	#967-SERIES STRAIGHT SLEEVE BUSHING (TRANSITIONAL FIT)	#966-SERIES DEMOUNTABLE SHOULDER BUSHING (TAP FIT)
	BORE SIZE	BORE SIZE	BORE SIZE	BORE SIZE
19mm	18.977 / 18.946	N/A	36.005 / 35.992	N/A
25mm	24.979 / 24.948	24.963 / 24.950	44.006 / 43.993	43.972 / 43.960
32mm	31.966 / 31.941	31.963 / 31.950	54.005 / 53.993	53.972 / 53.960
40mm	39.967 / 39.942	39.964 / 39.952	65.006 / 64.994	64.973 / 64.961
44mm	43.968 / 43.942	43.962 / 43.949	74.005 / 73.993	73.972 / 73.960
50mm	49.967 / 49.950	49.964 / 49.952	81.006 / 80.993	81.227 / 80.960
63mm	62.962 / 62.939	62.964 / 62.952	95.006 / 94.993	94.973 / 94.960
80mm	79.960 / 79.937	79.964 / 79.952	112.006 / 111.994	111.973 / 111.961

(UNLESS OTHERWISE NOTED, ALL DIMENSIONS ARE IN MILLIMETERS)

DIE SPRINGS INCH AND CUSTOM

DIE SPRINGS PRODUCT FEATURES

Same day shipments – we stock them so you don't have to

Inch sizes manufactured to industry standard colors

Reliable, trouble-free performance

Manufactured in an ISO 9001:2008 certified facility

Manufactured from spring-quality Chromium Silicon alloy, high-tensile strength steel in accordance with ASTM A1000-99 specifications

Optimal rectangular wire design

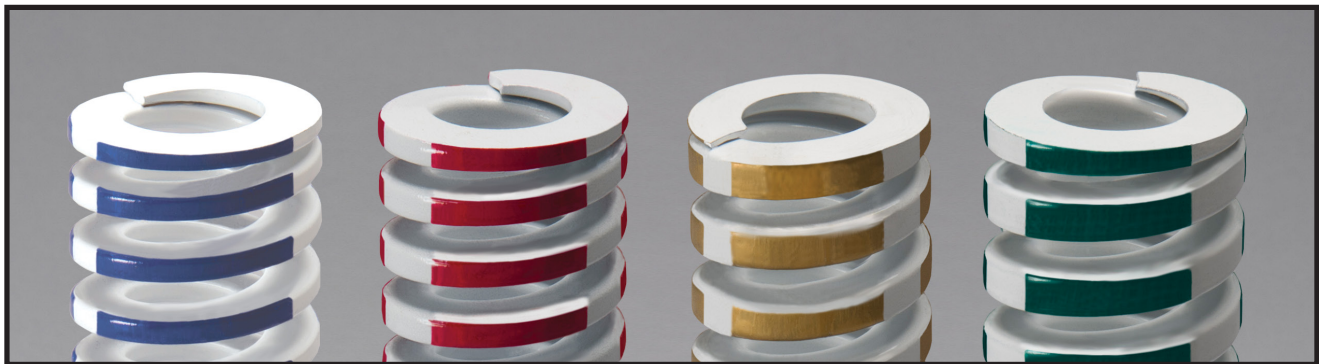

MEDIUM DUTY
Color Coded
Blue Stripe

MEDIUM HEAVY DUTY
Color Coded
Red Stripe

HEAVY DUTY
Color Coded
Gold Stripe

EXTRA HEAVY DUTY
Color Coded
Green Stripe

CUSTOM SPRINGS

A custom spring is any spring that has:

Unique physical attributes

- Special wire material, plating or paint
- Custom free lengths, diameters, solid heights, rates, number of coils or custom loads at a given deflection

Critical tolerances

Specific inspection or certification requirements

- Military specifications
- 100% inspection of critical characteristics

Statistical reports

Computer controlled multi-point tests



MEDIUM DUTY DIE SPRINGS

COLOR CODED BLUE STRIPE

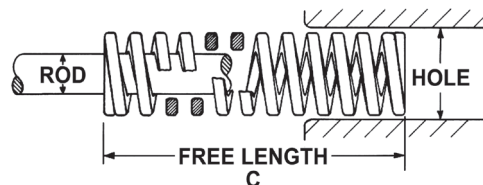
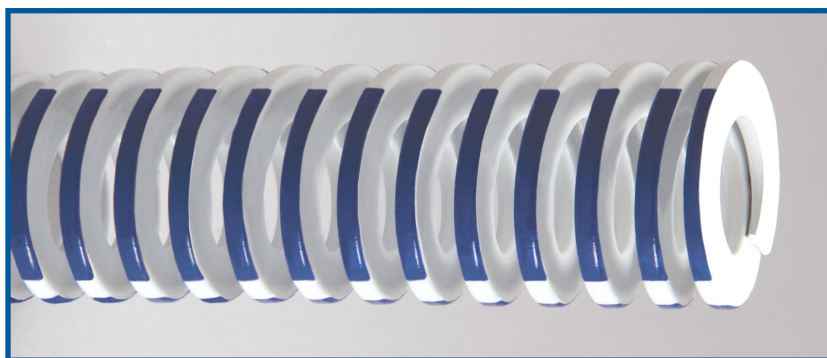

Hole Diam. (in)	Rod Diam. (in)	Free Length (in)	Wire Size (in)	CATALOG NUMBER	Pounds @ 1/10 inch defl.	Total Deflection Recommended for Long Life (25% of C)		Total Deflection Recommended for Avg. Life (35% of C)		Maximum Operating Deflection (40% of C)		* Max. Comp. Length (in)
						Load lbs.	Defl. in.	Load lbs.	Defl. in.	Load lbs.	Defl. in.	
3/8	3/16	1.00	0.040 X 0.070	9-0604-1	6.2	15.5	0.25	21.7	0.35	24.8	0.40	0.48
		1.25		9-0605-1	5.3	16.6	0.31	23.2	0.44	26.5	0.50	0.56
		1.50		9-0606-1	4.2	15.6	0.38	21.8	0.53	24.9	0.60	0.68
		1.75		9-0607-1	3.5	15.3	0.44	21.4	0.61	24.5	0.70	0.78
		2.00		9-0608-1	2.9	14.5	0.50	20.3	0.70	23.2	0.80	0.94
		2.50		9-0610-1	2.4	15.3	0.63	21.4	0.88	24.4	1.00	1.12
		3.00		9-0612-1	2.1	15.8	0.75	22.1	1.05	25.2	1.20	1.40
		12.00		9-0648-1	0.6	16.8	3.00	23.5	4.20	26.9	4.80	5.11
1/2	9/32	1.00	0.052 X 0.095	9-0804-1	10.7	26.8	0.25	37.5	0.35	42.8	0.40	0.45
		1.25		9-0805-1	8.2	25.6	0.31	35.9	0.44	41.0	0.50	0.55
		1.50		9-0806-1	6.8	25.5	0.38	35.7	0.53	40.8	0.60	0.66
		1.75		9-0807-1	6.0	26.3	0.44	36.8	0.61	42.0	0.70	0.73
		2.00		9-0808-1	5.3	26.5	0.50	37.1	0.70	42.4	0.80	0.82
		2.50		9-0810-1	4.3	26.9	0.63	37.6	0.88	43.0	1.00	1.02
		3.00		9-0812-1	3.4	25.5	0.75	35.7	1.05	40.8	1.20	1.25
		3.50		9-0814-1	2.9	25.4	0.88	35.5	1.23	40.6	1.40	1.42
		4.50		9-0818-1	2.4	27.0	1.13	37.8	1.58	43.2	1.80	1.82
		5.50		9-0822-1	2.0	27.5	1.38	38.5	1.93	44.0	2.20	2.22
		6.50		9-0826-1	1.4	22.8	1.63	31.9	2.28	36.4	2.60	2.65
		7.50		9-0830-1	1.2	22.5	1.88	31.5	2.63	36.0	3.00	3.27
12.00	9-0848-1	0.7	21.0	3.00	29.4	4.20	33.6	4.80	5.24			
5/8	11/32	1.00	0.068 X 0.117	9-1004-1	17.0	42.5	0.25	59.5	0.35	68.0	0.40	0.50
		1.25		9-1005-1	13.0	40.6	0.31	56.9	0.44	65.0	0.50	0.62
		1.50		9-1006-1	11.1	41.6	0.38	58.3	0.53	66.6	0.60	0.69
		1.75		9-1007-1	9.6	42.0	0.44	58.8	0.61	67.2	0.70	0.80
		2.00		9-1008-1	8.8	44.0	0.50	61.6	0.70	70.4	0.80	0.89
		2.50		9-1010-1	6.3	39.4	0.63	55.1	0.88	63.0	1.00	1.16
		3.00		9-1012-1	5.6	42.0	0.75	58.8	1.05	67.2	1.20	1.27
		3.50		9-1014-1	4.8	42.0	0.88	58.8	1.23	67.2	1.40	1.46
		4.00		9-1016-1	4.4	44.0	1.00	61.6	1.40	70.4	1.60	1.65
		12.00		9-1048-1	1.5	45.6	3.00	63.8	4.20	73.0	4.80	4.83
3/4	3/8	1.00	0.085 X 0.155	9-1204-1	31.8	79.5	0.25	111.3	0.35	127.2	0.40	0.50
		1.25		9-1205-1	25.6	80.0	0.31	112.0	0.44	128.0	0.50	0.65
		1.50		9-1206-1	20.0	75.0	0.38	105.0	0.53	120.0	0.60	0.77
		1.75		9-1207-1	17.6	77.0	0.44	107.8	0.61	123.2	0.70	0.88
		2.00		9-1208-1	14.4	72.0	0.50	100.8	0.70	115.2	0.80	1.03
		2.50		9-1210-1	12.0	75.0	0.63	105.0	0.88	120.0	1.00	1.28
		3.00		9-1212-1	9.6	72.0	0.75	100.8	1.05	115.2	1.20	1.49
		3.50		9-1214-1	8.0	70.0	0.88	98.0	1.23	112.0	1.40	1.74
		4.00		9-1216-1	7.2	72.0	1.00	100.8	1.40	115.2	1.60	1.99
		4.50		9-1218-1	6.4	72.0	1.13	100.8	1.58	115.2	1.80	2.24
		5.00		9-1220-1	6.0	75.0	1.25	105.0	1.75	120.0	2.00	2.48
		5.50		9-1222-1	5.5	75.6	1.38	105.9	1.93	121.0	2.20	2.72
		6.00		9-1224-1	5.0	75.0	1.50	105.0	2.10	120.0	2.40	2.97
		6.50		9-1226-1	4.5	73.1	1.63	102.4	2.28	117.0	2.60	3.20
		7.50		9-1230-1	3.8	71.3	1.88	99.8	2.63	114.0	3.00	3.64
		12.00		9-1248-1	2.4	72.0	3.00	100.8	4.20	115.2	4.80	5.84

* NOTE: For design purposes only. We do not recommend deflecting a spring to maximum deflection.

INCH STANDARD COLOR CODED BLUE STRIPE

Hole Diam. (in)	Rod Diam. (in)	Free Length (in)	Wire Size (in)	CATALOG NUMBER	Pounds @ 1/10 inch defl.	Total Deflection Recommended for Long Life (25% of C)		Total Deflection Recommended for Avg. Life (35% of C)		Maximum Operating Deflection (40% of C)		* Max. Comp. Length (in)			
						Load lbs.	Defl. in.	Load lbs.	Defl. in.	Load lbs.	Defl. in.				
1	1/2	1.00	0.105 X 0.212	9-1604-1	55.0	137.5	0.25	192.5	0.35	220.0	0.40	0.51			
		1.25		9-1605-1	45.0	140.6	0.31	196.9	0.44	225.0	0.50	0.66			
		1.50		9-1606-1	35.4	132.8	0.38	185.9	0.53	212.4	0.60	0.78			
		1.75		9-1607-1	30.0	131.3	0.44	183.8	0.61	210.0	0.70	0.90			
		2.00		9-1608-1	26.0	130.0	0.50	182.0	0.70	208.0	0.80	1.02			
		2.50		9-1610-1	20.2	126.3	0.63	176.8	0.88	202.0	1.00	1.27			
		3.00		9-1612-1	16.5	123.8	0.75	173.3	1.05	198.0	1.20	1.50			
		3.50		9-1614-1	15.0	131.3	0.88	183.8	1.23	210.0	1.40	1.75			
		4.00		9-1616-1	12.0	120.0	1.00	168.0	1.40	192.0	1.60	2.00			
		4.50		9-1618-1	10.5	118.1	1.13	165.4	1.58	189.0	1.80	2.25			
		5.00		9-1620-1	9.6	120.0	1.25	168.0	1.75	192.0	2.00	2.49			
		5.50		9-1622-1	8.8	121.0	1.38	169.4	1.93	193.6	2.20	2.74			
		6.00		9-1624-1	8.0	120.0	1.50	168.0	2.10	192.0	2.40	2.96			
		7.00		9-1628-1	7.2	126.0	1.75	176.4	2.45	201.6	2.80	3.48			
		8.00		9-1632-1	6.0	120.0	2.00	168.0	2.80	192.0	3.20	3.86			
12.00	9-1648-1	4.0	120.0	3.00	168.0	4.20	192.0	4.80	5.76						
1-1/4	5/8	1.50	0.125 X 0.270	9-2006-1	51.0	191.3	0.38	267.8	0.53	306.0	0.60	0.75			
		1.75		9-2007-1	42.4	185.5	0.44	259.7	0.61	296.8	0.70	0.88			
		2.00		9-2008-1	36.0	180.0	0.50	252.0	0.70	288.0	0.80	1.05			
		2.50		9-2010-1	28.8	180.0	0.63	252.0	0.88	288.0	1.00	1.25			
		3.00		9-2012-1	24.0	180.0	0.75	252.0	1.05	288.0	1.20	1.46			
		3.50		9-2014-1	20.0	175.0	0.88	245.0	1.23	280.0	1.40	1.70			
		4.00		9-2016-1	17.6	176.0	1.00	246.4	1.40	281.6	1.60	1.95			
		4.50		9-2018-1	16.0	180.0	1.13	252.0	1.58	288.0	1.80	2.20			
		5.00		9-2020-1	13.6	170.0	1.25	238.0	1.75	272.0	2.00	2.44			
		5.50		9-2022-1	12.8	176.0	1.38	246.4	1.93	281.6	2.20	2.72			
		6.00		9-2024-1	12.0	180.0	1.50	252.0	2.10	288.0	2.40	2.98			
		7.00		9-2028-1	10.4	182.0	1.75	254.8	2.45	291.2	2.80	3.50			
		8.00		9-2032-1	8.8	176.0	2.00	246.4	2.80	281.6	3.20	3.98			
		10.00		9-2040-1	7.2	180.0	2.50	252.0	3.50	288.0	4.00	4.98			
		12.00		9-2048-1	6.0	180.0	3.00	252.0	4.20	288.0	4.80	5.98			
1-1/2	3/4	2.00	0.158 X 0.315	9-2408-1	54.7	273.5	0.50	382.9	0.70	437.6	0.80	1.03			
		2.50		9-2410-1	44.7	279.4	0.63	391.1	0.88	447.0	1.00	1.27			
		3.00		9-2412-1	36.0	270.0	0.75	378.0	1.05	432.0	1.20	1.52			
		3.50		9-2414-1	30.0	262.5	0.88	367.5	1.23	420.0	1.40	1.74			
		4.00		9-2416-1	27.0	270.0	1.00	378.0	1.40	432.0	1.60	1.99			
		4.50		9-2418-1	23.0	258.8	1.13	362.3	1.58	414.0	1.80	2.22			
		5.00		9-2420-1	21.0	262.5	1.25	367.5	1.75	420.0	2.00	2.46			
		5.50		9-2422-1	18.5	254.4	1.38	356.1	1.93	407.0	2.20	2.72			
		6.00		9-2424-1	17.0	255.0	1.50	357.0	2.10	408.0	2.40	2.96			
		7.00		9-2428-1	14.5	253.8	1.75	355.3	2.45	406.0	2.80	3.40			
		8.00		9-2432-1	12.8	256.0	2.00	358.4	2.80	409.6	3.20	3.90			
		10.00		9-2440-1	10.0	250.0	2.50	350.0	3.50	400.0	4.00	4.86			
		12.00		9-2448-1	8.2	246.0	3.00	344.4	4.20	393.6	4.80	5.86			
		2		1	2.50	0.215 X 0.445	9-3210-1	100.0	625.0	0.63	875.0	0.88	1000.0	1.00	1.37
					3.00		9-3212-1	83.0	622.5	0.75	871.5	1.05	996.0	1.20	1.58
3.50	9-3214-1		65.8		575.8		0.88	806.1	1.23	921.2	1.40	1.84			
4.00	9-3216-1		60.0		600.0		1.00	840.0	1.40	960.0	1.60	2.08			
4.50	9-3218-1		53.0		596.3		1.13	834.8	1.58	954.0	1.80	2.20			
5.00	9-3220-1		47.0		587.5		1.25	822.5	1.75	940.0	2.00	2.58			
5.50	9-3222-1		39.8		547.3		1.38	766.2	1.93	875.6	2.20	2.88			
6.00	9-3224-1		39.0		585.0		1.50	819.0	2.10	936.0	2.40	3.03			
7.00	9-3228-1		31.6		553.0		1.75	774.2	2.45	884.8	2.80	3.58			
8.00	9-3232-1		28.5		570.0		2.00	798.0	2.80	912.0	3.20	4.05			
10.00	9-3240-1		20.8		520.0		2.50	728.0	3.50	832.0	4.00	5.00			
12.00	9-3248-1		17.5		525.0		3.00	735.0	4.20	840.0	4.80	6.17			

* NOTE: For design purposes only. We do not recommend deflecting a spring to maximum deflection.

MEDIUM HEAVY DUTY DIE SPRINGS

COLOR CODED RED STRIPE

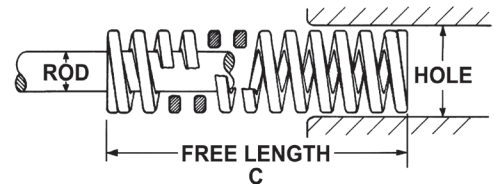
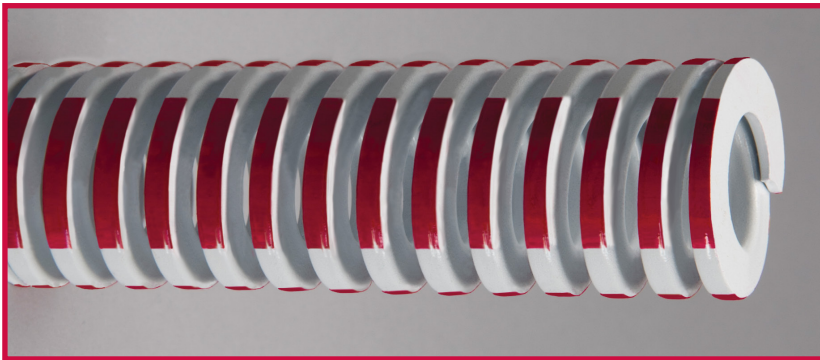

Hole Diam. (in)	Rod Diam. (in)	Free Length (in)	Wire Size (in)	CATALOG NUMBER	Pounds @ 1/10 inch defl.	Total Deflection Recommended for Long Life (20% of C)		Total Deflection Recommended for Avg. Life (25% of C)		Maximum Operating Deflection (35% of C)		* Max. Comp. Length (in)
						Load lbs.	Defl. in.	Load lbs.	Defl. in.	Load lbs.	Defl. in.	
3/8	3/16	1.00	0.045 X 0.070	9-0604-2	9.0	18.0	0.20	22.5	0.25	31.5	0.35	0.58
		1.25		9-0605-2	7.3	18.3	0.25	22.8	0.31	31.9	0.44	0.71
		1.50		9-0606-2	6.7	20.1	0.30	25.1	0.38	35.2	0.53	0.85
		1.75		9-0607-2	5.7	20.0	0.35	24.9	0.44	34.9	0.61	0.95
		2.00		9-0608-2	5.0	20.0	0.40	25.0	0.50	35.0	0.70	1.09
		2.50		9-0610-2	4.0	20.0	0.50	25.0	0.63	35.0	0.88	1.36
		3.00		9-0612-2	3.0	18.0	0.60	22.5	0.75	31.5	1.05	1.69
		12.00	9-0648-2	0.8	19.2	2.40	24.0	3.00	33.6	4.20	6.46	
1/2	9/32	1.00	0.060 X 0.095	9-0804-2	16.6	33.2	0.20	41.5	0.25	58.1	0.35	0.50
		1.25		9-0805-2	13.0	32.5	0.25	40.6	0.31	56.9	0.44	0.61
		1.50		9-0806-2	9.9	29.7	0.30	37.1	0.38	52.0	0.53	0.72
		1.75		9-0807-2	8.5	29.8	0.35	37.2	0.44	52.1	0.61	0.84
		2.00		9-0808-2	7.5	30.0	0.40	37.5	0.50	52.5	0.70	0.95
		2.50		9-0810-2	6.0	30.0	0.50	37.5	0.63	52.5	0.88	1.18
		3.00		9-0812-2	5.5	33.0	0.60	41.3	0.75	57.8	1.05	1.40
		3.50		9-0814-2	4.0	28.0	0.70	35.0	0.88	49.0	1.23	1.68
		12.00		9-0848-2	1.2	28.8	2.40	36.0	3.00	50.4	4.20	5.68
5/8	11/32	1.00	0.086 X 0.112	9-1004-2	30.0	60.0	0.20	75.0	0.25	105.0	0.35	0.56
		1.25		9-1005-2	21.5	53.8	0.25	67.2	0.31	94.1	0.44	0.70
		1.50		9-1006-2	19.2	57.6	0.30	72.0	0.38	100.8	0.53	0.79
		1.75		9-1007-2	16.8	58.8	0.35	73.5	0.44	102.9	0.61	0.92
		2.00		9-1008-2	14.8	59.2	0.40	74.0	0.50	103.6	0.70	1.00
		2.50		9-1010-2	11.5	57.5	0.50	71.9	0.63	100.6	0.88	1.22
		3.00		9-1012-2	10.0	60.0	0.60	75.0	0.75	105.0	1.05	1.43
		3.50		9-1014-2	8.5	59.5	0.70	74.4	0.88	104.1	1.23	1.69
		4.00		9-1016-2	7.6	60.8	0.80	76.0	1.00	106.4	1.40	1.92
		12.00		9-1048-2	2.6	62.4	2.40	78.0	3.00	109.2	4.20	5.70
3/4	3/8	1.00	0.100 X 0.155	9-1204-2	50.0	100.0	0.20	125.0	0.25	175.0	0.35	0.58
		1.25		9-1205-2	38.0	95.0	0.25	118.8	0.31	166.3	0.44	0.72
		1.50		9-1206-2	32.0	96.0	0.30	120.0	0.38	168.0	0.53	0.87
		1.75		9-1207-2	28.5	99.8	0.35	124.7	0.44	174.6	0.61	1.02
		2.00		9-1208-2	24.8	99.2	0.40	124.0	0.50	173.6	0.70	1.16
		2.50		9-1210-2	19.2	96.0	0.50	120.0	0.63	168.0	0.88	1.46
		3.00		9-1212-2	14.4	86.4	0.60	108.0	0.75	151.2	1.05	1.74
		3.50		9-1214-2	12.8	89.6	0.70	112.0	0.88	156.8	1.23	2.02
		4.00		9-1216-2	12.0	96.0	0.80	120.0	1.00	168.0	1.40	2.31
		4.50		9-1218-2	11.0	99.0	0.90	123.8	1.13	173.3	1.58	2.62
		5.00		9-1220-2	9.0	90.0	1.00	112.5	1.25	157.5	1.75	2.86
		5.50		9-1222-2	8.0	88.0	1.10	110.0	1.38	154.0	1.93	3.15
		6.00		9-1224-2	7.5	90.0	1.20	112.5	1.50	157.5	2.10	3.45
		12.00		9-1248-2	3.6	86.4	2.40	108.0	3.00	151.2	4.20	6.78

* **NOTE:** For design purposes only. We do not recommend deflecting a spring to maximum deflection.

INCH STANDARD COLOR CODED RED STRIPE

Hole Diam. (in)	Rod Diam. (in)	Free Length (in)	Wire Size (in)	CATALOG NUMBER	Pounds @ 1/10 inch defl.	Total Deflection Recommended for Long Life (20% of C)		Total Deflection Recommended for Avg. Life (25% of C)		Maximum Operating Deflection (35% of C)		* Max. Comp. Length (in)
						Load lbs.	Defl. in.	Load lbs.	Defl. in.	Load lbs.	Defl. in.	
1	1/2	1.00	0.125 X 0.214	9-1604-2	76.0	152.0	0.20	190.0	0.25	266.0	0.35	0.61
		1.25		9-1605-2	62.4	156.0	0.25	195.0	0.31	273.0	0.44	0.75
		1.50		9-1606-2	49.6	148.8	0.30	186.0	0.38	260.4	0.53	0.89
		1.75		9-1607-2	44.0	154.0	0.35	192.5	0.44	269.5	0.61	1.02
		2.00		9-1608-2	40.0	160.0	0.40	200.0	0.50	280.0	0.70	1.15
		2.50		9-1610-2	31.0	155.0	0.50	193.8	0.63	271.3	0.88	1.44
		3.00		9-1612-2	25.0	150.0	0.60	187.5	0.75	262.5	1.05	1.73
		3.50		9-1614-2	21.6	151.2	0.70	189.0	0.88	264.6	1.23	2.02
		4.00		9-1616-2	18.4	147.2	0.80	184.0	1.00	257.6	1.40	2.30
		4.50		9-1618-2	17.0	153.0	0.90	191.3	1.13	267.8	1.58	2.59
		5.00		9-1620-2	14.4	144.0	1.00	180.0	1.25	252.0	1.75	2.88
		5.50		9-1622-2	12.8	140.8	1.10	176.0	1.38	246.4	1.93	3.16
		6.00		9-1624-2	12.0	144.0	1.20	180.0	1.50	252.0	2.10	3.45
		7.00		9-1628-2	10.0	140.0	1.40	175.0	1.75	245.0	2.45	4.03
8.00	9-1632-2	8.8	140.8	1.60	176.0	2.00	246.4	2.80	4.60			
12.00	9-1648-2	6.2	148.8	2.40	186.0	3.00	260.4	4.20	6.70			
1-1/4	5/8	1.50	0.165 X 0.270	9-2006-2	113.4	340.2	0.30	425.3	0.38	595.4	0.53	0.92
		1.75		9-2007-2	94.5	330.8	0.35	413.4	0.44	578.8	0.61	1.07
		2.00		9-2008-2	81.0	324.0	0.40	405.0	0.50	567.0	0.70	1.22
		2.50		9-2010-2	62.4	312.0	0.50	390.0	0.63	546.0	0.88	1.55
		3.00		9-2012-2	51.2	307.2	0.60	384.0	0.75	537.6	1.05	1.83
		3.50		9-2014-2	43.5	304.5	0.70	380.6	0.88	532.9	1.23	2.12
		4.00		9-2016-2	36.8	294.4	0.80	368.0	1.00	515.2	1.40	2.43
		4.50		9-2018-2	32.0	288.0	0.90	360.0	1.13	504.0	1.58	2.68
		5.00		9-2020-2	29.0	290.0	1.00	362.5	1.25	507.5	1.75	2.94
		5.50		9-2022-2	26.4	290.4	1.10	363.0	1.38	508.2	1.93	3.22
		6.00		9-2024-2	25.0	300.0	1.20	375.0	1.50	525.0	2.10	3.58
		7.00		9-2028-2	20.0	280.0	1.40	350.0	1.75	490.0	2.45	4.10
		8.00		9-2032-2	18.4	294.4	1.60	368.0	2.00	515.2	2.80	4.76
		10.00		9-2040-2	14.5	290.0	2.00	362.5	2.50	507.5	3.50	5.78
12.00	9-2048-2	12.1	290.4	2.40	363.0	3.00	508.2	4.20	6.94			
1-1/2	3/4	2.00	0.191 X 0.320	9-2408-2	104.0	416.0	0.40	520.0	0.50	728.0	0.70	1.21
		2.50		9-2410-2	81.5	407.5	0.50	509.4	0.63	713.1	0.88	1.51
		3.00		9-2412-2	62.4	374.4	0.60	468.0	0.75	655.2	1.05	1.75
		3.50		9-2414-2	52.8	369.6	0.70	462.0	0.88	646.8	1.23	2.08
		4.00		9-2416-2	47.3	378.4	0.80	473.0	1.00	662.2	1.40	2.31
		4.50		9-2418-2	41.6	374.4	0.90	468.0	1.13	655.2	1.58	2.58
		5.00		9-2420-2	36.8	368.0	1.00	460.0	1.25	644.0	1.75	2.82
		5.50		9-2422-2	33.6	369.6	1.10	462.0	1.38	646.8	1.93	3.05
		6.00		9-2424-2	30.4	364.8	1.20	456.0	1.50	638.4	2.10	3.45
		7.00		9-2428-2	26.4	369.6	1.40	462.0	1.75	646.8	2.45	3.89
		8.00		9-2432-2	22.0	352.0	1.60	440.0	2.00	616.0	2.80	4.45
		10.00		9-2440-2	17.6	352.0	2.00	440.0	2.50	616.0	3.50	5.55
		12.00		9-2448-2	14.4	345.6	2.40	432.0	3.00	604.8	4.20	6.80
		2		1	2.50	0.235 X 0.440	9-3210-2	118.4	592.0	0.50	740.0	0.63
3.00	9-3212-2		96.0		576.0		0.60	720.0	0.75	1008.0	1.05	1.77
3.50	9-3214-2		80.0		560.0		0.70	700.0	0.88	980.0	1.23	2.05
4.00	9-3216-2		66.4		531.2		0.80	664.0	1.00	929.6	1.40	2.32
4.50	9-3218-2		60.0		540.0		0.90	675.0	1.13	945.0	1.58	2.60
5.00	9-3220-2		55.1		551.0		1.00	688.8	1.25	964.3	1.75	2.92
5.50	9-3222-2		49.7		546.7		1.10	683.4	1.38	956.7	1.93	3.18
6.00	9-3224-2		45.3		543.6		1.20	679.5	1.50	951.3	2.10	3.46
7.00	9-3228-2		38.5		539.0		1.40	673.8	1.75	943.3	2.45	4.05
8.00	9-3232-2		33.5		536.0		1.60	670.0	2.00	938.0	2.80	4.62
10.00	9-3240-2		26.0		520.0		2.00	650.0	2.50	910.0	3.50	5.75
12.00	9-3248-2		21.9		525.6		2.40	657.0	3.00	919.8	4.20	6.88

* NOTE: For design purposes only. We do not recommend deflecting a spring to maximum deflection.

HEAVY DUTY DIE SPRINGS

COLOR CODED GOLD STRIPE

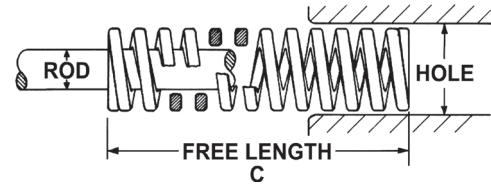
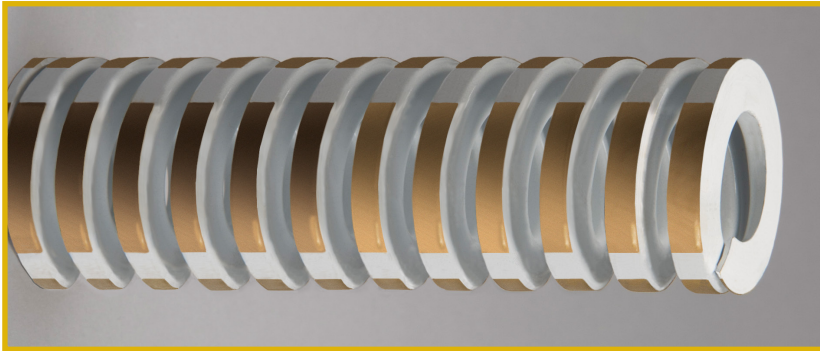

Hole Diam. (in)	Rod Diam. (in)	Free Length (in)	Wire Size (in)	CATALOG NUMBER	Pounds @ 1/10 inch defl.	Total Deflection Recommended for Long Life (15% of C)		Total Deflection Recommended for Avg. Life (20% of C)		Maximum Operating Deflection (28% of C)		* Max. Comp. Length (in)
						Load lbs.	Defl. in.	Load lbs.	Defl. in.	Load lbs.	Defl. in.	
3/8	3/16	1.00	0.053 X 0.071	9-0604-3	11.6	17.4	0.15	23.2	0.20	32.5	0.28	0.65
		1.25		9-0605-3	9.8	18.4	0.19	24.5	0.25	34.3	0.35	0.79
		1.50		9-0606-3	8.3	18.7	0.23	24.9	0.30	34.9	0.42	0.87
		1.75		9-0607-3	8.2	21.5	0.26	28.7	0.35	40.2	0.49	0.99
		2.00		9-0608-3	7.1	21.3	0.30	28.4	0.40	39.8	0.56	1.14
		2.50		9-0610-3	5.5	20.6	0.38	27.5	0.50	38.5	0.70	1.41
		3.00		9-0612-3	4.2	18.9	0.45	25.2	0.60	35.3	0.84	1.72
		12.00		9-0648-3	1.1	20.5	1.80	27.4	2.40	38.3	3.36	6.74
1/2	9/32	1.00	0.071 X 0.095	9-0804-3	23.6	35.4	0.15	47.2	0.20	66.1	0.28	0.67
		1.25		9-0805-3	18.6	34.9	0.19	46.5	0.25	65.1	0.35	0.70
		1.50		9-0806-3	15.5	34.9	0.23	46.5	0.30	65.1	0.42	0.81
		1.75		9-0807-3	13.8	36.2	0.26	48.3	0.35	67.6	0.49	1.00
		2.00		9-0808-3	11.0	33.0	0.30	44.0	0.40	61.6	0.56	1.05
		2.50		9-0810-3	8.4	31.5	0.38	42.0	0.50	58.8	0.70	1.32
		3.00		9-0812-3	7.4	33.3	0.45	44.4	0.60	62.2	0.84	1.54
		12.00		9-0814-3	6.0	31.5	0.53	42.0	0.70	58.8	0.98	1.82
5/8	11/32	1.00	0.096 X 0.115	9-1004-3	43.0	64.5	0.15	86.0	0.20	120.4	0.28	0.62
		1.25		9-1005-3	32.0	60.0	0.19	80.0	0.25	112.0	0.35	0.78
		1.50		9-1006-3	27.7	62.3	0.23	83.1	0.30	116.3	0.42	0.90
		1.75		9-1007-3	24.0	63.0	0.26	84.0	0.35	117.6	0.49	1.01
		2.00		9-1008-3	20.8	62.4	0.30	83.2	0.40	116.5	0.56	1.18
		2.50		9-1010-3	16.6	62.3	0.38	83.0	0.50	116.2	0.70	1.44
		3.00		9-1012-3	14.0	63.0	0.45	84.0	0.60	117.6	0.84	1.68
		12.00		9-1014-3	11.9	62.5	0.53	83.3	0.70	116.6	0.98	1.95
3/4	3/8	1.00	0.130 X 0.155	9-1204-3	108.8	163.2	0.15	217.6	0.20	304.6	0.28	0.69
		1.25		9-1205-3	88.0	165.0	0.19	220.0	0.25	308.0	0.35	0.86
		1.50		9-1206-3	68.4	153.9	0.23	205.2	0.30	287.3	0.42	1.02
		1.75		9-1207-3	60.0	157.5	0.26	210.0	0.35	294.0	0.49	1.19
		2.00		9-1208-3	49.8	149.4	0.30	199.2	0.40	278.9	0.56	1.35
		2.50		9-1210-3	40.0	150.0	0.38	200.0	0.50	280.0	0.70	1.71
		3.00		9-1212-3	34.0	153.0	0.45	204.0	0.60	285.6	0.84	2.00
		3.50		9-1214-3	28.0	147.0	0.53	196.0	0.70	274.4	0.98	2.33
		4.00		9-1216-3	25.0	150.0	0.60	200.0	0.80	280.0	1.12	2.67
		4.50		9-1218-3	22.0	148.5	0.68	198.0	0.90	277.2	1.26	3.00
		5.00		9-1220-3	19.5	146.3	0.75	195.0	1.00	273.0	1.40	3.33
		5.50		9-1222-3	17.0	140.3	0.83	187.0	1.10	261.8	1.54	3.66
		6.00		9-1224-3	16.0	144.0	0.90	192.0	1.20	268.8	1.68	3.99
		12.00		9-1248-3	8.0	144.0	1.80	192.0	2.40	268.8	3.36	7.90

* NOTE: For design purposes only. We do not recommend deflecting a spring to maximum deflection.

INCH STANDARD COLOR CODED GOLD STRIPE

Hole Diam. (in)	Rod Diam. (in)	Free Length (in)	Wire Size (in)	CATALOG NUMBER	Pounds @ 1/10 inch defl.	Total Deflection Recommended for Long Life (15% of C)		Total Deflection Recommended for Avg. Life (20% of C)		Maximum Operating Deflection (28% of C)		* Max. Comp. Length (in)
						Load lbs.	Defl. in.	Load lbs.	Defl. in.	Load lbs.	Defl. in.	
1	1/2	1.00	0.165 X 0.216	9-1604-3	208.0	312.0	0.15	416.0	0.20	582.4	0.28	0.68
		1.25		9-1605-3	170.0	318.8	0.19	425.0	0.25	595.0	0.35	0.86
		1.50		9-1606-3	119.8	269.6	0.23	359.4	0.30	503.2	0.42	1.03
		1.75		9-1607-3	104.0	273.0	0.26	364.0	0.35	509.6	0.49	1.18
		2.00		9-1608-3	90.0	270.0	0.30	360.0	0.40	504.0	0.56	1.35
		2.50		9-1610-3	68.0	255.0	0.38	340.0	0.50	476.0	0.70	1.68
		3.00		9-1612-3	54.4	244.8	0.45	326.4	0.60	457.0	0.84	2.00
		3.50		9-1614-3	45.9	241.0	0.53	321.3	0.70	449.8	0.98	2.33
		4.00		9-1616-3	40.0	240.0	0.60	320.0	0.80	448.0	1.12	2.63
		4.50		9-1618-3	35.2	237.6	0.68	316.8	0.90	443.5	1.26	2.94
		5.00		9-1620-3	31.5	236.3	0.75	315.0	1.00	441.0	1.40	3.26
		5.50		9-1622-3	28.8	237.6	0.83	316.8	1.10	443.5	1.54	3.55
		6.00		9-1624-3	25.9	233.1	0.90	310.8	1.20	435.1	1.68	3.87
		7.00		9-1628-3	22.4	235.2	1.05	313.6	1.40	439.0	1.96	4.47
8.00	9-1632-3	19.2	230.4	1.20	307.2	1.60	430.1	2.24	5.16			
12.00	9-1648-3	12.5	225.0	1.80	300.0	2.40	420.0	3.36	7.80			
1-1/4	5/8	1.50	0.209 X 0.275	9-2006-3	212.0	477.0	0.23	636.0	0.30	890.4	0.42	1.01
		1.75		9-2007-3	181.0	475.1	0.26	633.5	0.35	886.9	0.49	1.17
		2.00		9-2008-3	149.6	448.8	0.30	598.4	0.40	837.8	0.56	1.34
		2.50		9-2010-3	117.2	439.5	0.38	586.0	0.50	820.4	0.70	1.68
		3.00		9-2012-3	95.0	427.5	0.45	570.0	0.60	798.0	0.84	2.02
		3.50		9-2014-3	77.0	404.3	0.53	539.0	0.70	754.6	0.98	2.30
		4.00		9-2016-3	66.4	398.4	0.60	531.2	0.80	743.7	1.12	2.66
		4.50		9-2018-3	58.4	394.2	0.68	525.6	0.90	735.8	1.26	2.99
		5.00		9-2020-3	53.0	397.5	0.75	530.0	1.00	742.0	1.40	3.30
		5.50		9-2022-3	47.2	389.4	0.83	519.2	1.10	726.9	1.54	3.62
		6.00		9-2024-3	42.9	386.1	0.90	514.8	1.20	720.7	1.68	3.95
		7.00		9-2028-3	36.8	386.4	1.05	515.2	1.40	721.3	1.96	4.60
		8.00		9-2032-3	32.8	393.6	1.20	524.8	1.60	734.7	2.24	5.25
		10.00		9-2040-3	25.6	384.0	1.50	512.0	2.00	716.8	2.80	6.40
12.00	9-2048-3	20.8	374.4	1.80	499.2	2.40	698.9	3.36	7.62			
1-1/2	3/4	2.00	0.245 X 0.328	9-2408-3	195.4	586.2	0.30	781.6	0.40	1094.2	0.56	1.34
		2.50		9-2410-3	155.0	581.3	0.38	775.0	0.50	1085.0	0.70	1.68
		3.00		9-2412-3	128.0	576.0	0.45	768.0	0.60	1075.2	0.84	1.99
		3.50		9-2414-3	106.4	558.6	0.53	744.8	0.70	1042.7	0.98	2.30
		4.00		9-2416-3	91.2	547.2	0.60	729.6	0.80	1021.4	1.12	2.62
		4.50		9-2418-3	78.4	529.2	0.68	705.6	0.90	987.8	1.26	2.91
		5.00		9-2420-3	71.2	534.0	0.75	712.0	1.00	996.8	1.40	3.22
		5.50		9-2422-3	64.0	528.0	0.83	704.0	1.10	985.6	1.54	3.54
		6.00		9-2424-3	58.4	525.6	0.90	700.8	1.20	981.1	1.68	3.82
		7.00		9-2428-3	49.6	520.8	1.05	694.4	1.40	972.2	1.96	4.44
		8.00		9-2432-3	43.2	518.4	1.20	691.2	1.60	967.7	2.24	5.02
		10.00		9-2440-3	34.4	516.0	1.50	688.0	2.00	963.2	2.80	6.26
		12.00		9-2448-3	28.8	518.4	1.80	691.2	2.40	967.7	3.36	7.50
		2		1	2.50	.305 X 0.450	9-3210-3	253.0	948.8	0.38	1265.0	0.50
3.00	9-3212-3		200.0		900.0		0.45	1200.0	0.60	1680.0	0.84	2.05
3.50	9-3214-3		170.0		892.5		0.53	1190.0	0.70	1666.0	0.98	2.37
4.00	9-3216-3		146.0		876.0		0.60	1168.0	0.80	1635.2	1.12	2.67
4.50	9-3218-3		120.0		810.0		0.68	1080.0	0.90	1512.0	1.26	2.98
5.00	9-3220-3		110.0		825.0		0.75	1100.0	1.00	1540.0	1.40	3.32
5.50	9-3222-3		100.0		825.0		0.83	1100.0	1.10	1540.0	1.54	3.65
6.00	9-3224-3		93.0		837.0		0.90	1116.0	1.20	1562.4	1.68	3.97
7.00	9-3228-3		79.0		829.5		1.05	1106.0	1.40	1548.4	1.96	4.61
8.00	9-3232-3		69.0		828.0		1.20	1104.0	1.60	1545.6	2.24	5.22
10.00	9-3240-3		54.4		816.0		1.50	1088.0	2.00	1523.2	2.80	6.55
12.00	9-3248-3	42.0	756.0	1.80	1008.0	2.40	1411.2	3.36	7.75			

* NOTE: For design purposes only. We do not recommend deflecting a spring to maximum deflection.

EXTRA HEAVY DUTY DIE SPRINGS

COLOR CODED GREEN STRIPE

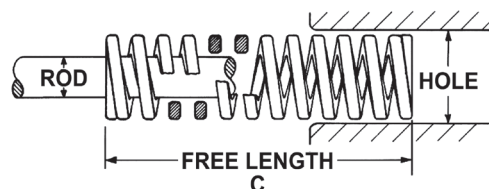
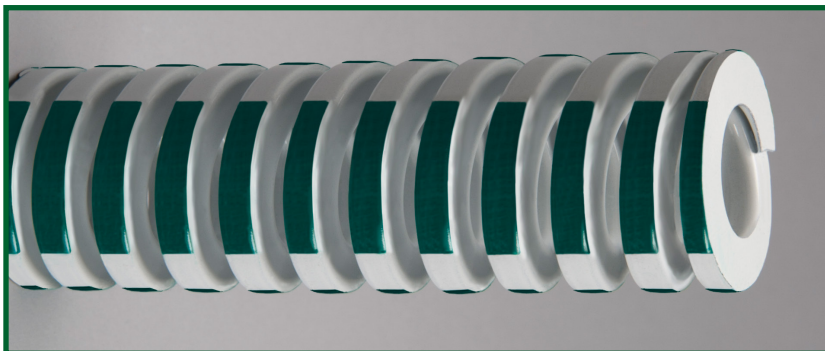

Hole Diam. (in)	Rod Diam. (in)	Free Length (in)	Wire Size (in)	CATALOG NUMBER	Pounds @ 1/10 inch defl.	Total Deflection Recommended for Long Life (15% of C)		Total Deflection Recommended for Avg. Life (17% of C)		Maximum Operating Deflection (25% of C)		* Max. Comp. Length (in)
						Load lbs.	Defl. in.	Load lbs.	Defl. in.	Load lbs.	Defl. in.	
3/8	3/16	1.00	0.063 X 0.073	9-0604-4	20.5	30.8	0.15	34.9	0.17	51.3	0.25	0.67
		1.25		9-0605-4	16.0	30.0	0.19	34.0	0.21	50.0	0.31	0.86
		1.50		9-0606-4	12.5	28.1	0.23	31.9	0.26	46.9	0.38	1.03
		1.75		9-0607-4	11.1	29.1	0.26	33.0	0.30	48.6	0.44	1.22
		2.00		9-0608-4	9.0	27.0	0.30	30.6	0.34	45.0	0.50	1.38
		2.50		9-0610-4	7.0	26.3	0.38	29.8	0.43	43.8	0.63	1.71
		3.00		9-0612-4	6.3	28.4	0.45	32.1	0.51	47.3	0.75	2.05
		12.00		9-0648-4	1.5	27.0	1.80	30.6	2.04	45.0	3.00	7.98
1/2	9/32	1.00	0.088 X 0.090	9-0804-4	32.0	48.0	0.15	54.4	0.17	80.0	0.25	0.69
		1.25		9-0805-4	24.2	45.4	0.19	51.4	0.21	75.6	0.31	0.86
		1.50		9-0806-4	20.0	45.0	0.23	51.0	0.26	75.0	0.38	1.03
		1.75		9-0807-4	17.0	44.6	0.26	50.6	0.30	74.4	0.44	1.20
		2.00		9-0808-4	14.5	43.5	0.30	49.3	0.34	72.5	0.50	1.36
		2.50		9-0810-4	11.5	43.1	0.38	48.9	0.43	71.9	0.63	1.65
		3.00		9-0812-4	9.4	42.3	0.45	47.9	0.51	70.5	0.75	1.99
		3.50		9-0814-4	8.0	42.0	0.53	47.6	0.60	70.0	0.88	2.30
12.00	9-0848-4	2.5	45.0	1.80	51.0	2.04	75.0	3.00	7.82			
5/8	11/32	1.00	0.115 X 0.120	9-1004-4	63.0	94.5	0.15	107.1	0.17	157.5	0.25	0.68
		1.25		9-1005-4	47.0	88.1	0.19	99.9	0.21	146.9	0.31	0.85
		1.50		9-1006-4	38.0	85.5	0.23	96.9	0.26	142.5	0.38	1.03
		1.75		9-1007-4	32.0	84.0	0.26	95.2	0.30	140.0	0.44	1.20
		2.00		9-1008-4	29.0	87.0	0.30	98.6	0.34	145.0	0.50	1.38
		2.50		9-1010-4	22.0	82.5	0.38	93.5	0.43	137.5	0.63	1.81
		3.00		9-1012-4	19.0	85.5	0.45	96.9	0.51	142.5	0.75	2.06
		3.50		9-1014-4	16.0	84.0	0.53	95.2	0.60	140.0	0.88	2.39
		4.00		9-1016-4	13.5	81.0	0.60	91.8	0.68	135.0	1.00	2.78
		12.00		9-1048-4	4.5	81.0	1.80	91.8	2.04	135.0	3.00	7.87
3/4	3/8	1.00	0.140 X 0.155	9-1204-4	140.0	210.0	0.15	238.0	0.17	350.0	0.25	0.71
		1.25		9-1205-4	110.0	206.3	0.19	233.8	0.21	343.8	0.31	0.89
		1.50		9-1206-4	89.0	200.3	0.23	227.0	0.26	333.8	0.38	1.06
		1.75		9-1207-4	75.0	196.9	0.26	223.1	0.30	328.1	0.44	1.24
		2.00		9-1208-4	68.0	204.0	0.30	231.2	0.34	340.0	0.50	1.42
		2.50		9-1210-4	50.0	187.5	0.38	212.5	0.43	312.5	0.63	1.76
		3.00		9-1212-4	40.5	182.3	0.45	206.6	0.51	303.8	0.75	2.07
		3.50		9-1214-4	34.5	181.1	0.53	205.3	0.60	301.9	0.88	2.41
		4.00		9-1216-4	30.0	180.0	0.60	204.0	0.68	300.0	1.00	2.76
		4.50		9-1218-4	26.5	178.9	0.68	202.7	0.77	298.1	1.13	3.10
		5.00		9-1220-4	23.5	176.3	0.75	199.8	0.85	293.8	1.25	3.42
		5.50		9-1222-4	21.5	177.4	0.83	201.0	0.94	295.6	1.38	3.78
		6.00		9-1224-4	19.5	175.5	0.90	198.9	1.02	292.5	1.50	4.10
		12.00		9-1248-4	9.5	171.0	1.80	193.8	2.04	285.0	3.00	8.10

* NOTE: For design purposes only. We do not recommend deflecting a spring to maximum deflection.

INCH STANDARD COLOR CODED GREEN STRIPE

Hole Diam. (in)	Rod Diam. (in)	Free Length (in)	Wire Size (in)	CATALOG NUMBER	Pounds @ 1/10 inch defl.	Total Deflection Recommended for Long Life (15% of C)		Total Deflection Recommended for Avg. Life (17% of C)		Maximum Operating Deflection (25% of C)		* Max. Comp. Length (in)
						Load lbs.	Defl. in.	Load lbs.	Defl. in.	Load lbs.	Defl. in.	
1	1/2	1.50	0.182 X 0.215	9-1606-4	160.0	360.0	0.23	408.0	0.26	600.0	0.38	1.05
		2.00		9-1608-4	116.0	348.0	0.30	394.4	0.34	580.0	0.50	1.40
		2.50		9-1610-4	89.6	336.0	0.38	380.8	0.43	560.0	0.63	1.73
		3.00		9-1612-4	73.6	331.2	0.45	375.4	0.51	552.0	0.75	2.08
		3.50		9-1614-4	62.4	327.6	0.53	371.3	0.60	546.0	0.88	2.42
		4.00		9-1616-4	55.2	331.2	0.60	375.4	0.68	552.0	1.00	2.74
		4.50		9-1618-4	48.8	329.4	0.68	373.3	0.77	549.0	1.13	3.04
		5.00		9-1620-4	43.2	324.0	0.75	367.2	0.85	540.0	1.25	3.38
		6.00		9-1624-4	36.0	324.0	0.90	367.2	1.02	540.0	1.50	3.99
		12.00		9-1648-4	17.6	316.8	1.80	359.0	2.04	528.0	3.00	7.86
		1-1/4		5/8	2.00	0.226 X 0.280	9-2008-4	192.0	576.0	0.30	652.8	0.34
2.50	9-2010-4		146.2		548.3		0.38	621.4	0.43	913.8	0.63	1.74
3.00	9-2012-4		118.4		532.8		0.45	603.8	0.51	888.0	0.75	2.09
3.50	9-2014-4		100.8		529.2		0.53	599.8	0.60	882.0	0.88	2.43
4.00	9-2016-4		85.0		510.0		0.60	578.0	0.68	850.0	1.00	2.78
4.50	9-2018-4		78.4		529.2		0.68	599.8	0.77	882.0	1.13	3.12
5.00	9-2020-4		68.0		510.0		0.75	578.0	0.85	850.0	1.25	3.46
6.00	9-2024-4		56.0		504.0		0.90	571.2	1.02	840.0	1.50	4.11
8.00	9-2032-4		41.6		499.2		1.20	565.8	1.36	832.0	2.00	5.40
10.00	9-2040-4		33.6		504.0		1.50	571.2	1.70	840.0	2.50	6.75
12.00	9-2048-4		26.4		475.2		1.80	538.6	2.04	792.0	3.00	7.99
1-1/2	3/4	2.00	0.290 X 0.330	9-2408-4	370.0	1017.0	0.30	1152.6	0.34	1695.0	0.50	1.45
		2.50		9-2410-4	285.0	993.8	0.38	1126.3	0.43	1656.3	0.63	1.80
		3.00		9-2412-4	231.2	967.5	0.45	1096.5	0.51	1612.5	0.75	2.16
		3.50		9-2414-4	196.0	918.8	0.53	1041.3	0.60	1531.3	0.88	2.51
		4.00		9-2416-4	171.0	912.0	0.60	1033.6	0.68	1520.0	1.00	2.90
		4.50		9-2418-4	148.0	891.0	0.68	1009.8	0.77	1485.0	1.13	3.22
		5.00		9-2420-4	135.0	915.0	0.75	1037.0	0.85	1525.0	1.25	3.58
		6.00		9-2424-4	110.4	891.0	0.90	1009.8	1.02	1485.0	1.50	4.30
		8.00		9-2432-4	80.8	852.0	1.20	965.6	1.36	1420.0	2.00	5.72
		10.00		9-2440-4	65.0	855.0	1.50	969.0	1.70	1425.0	2.50	7.12
		12.00		9-2448-4	54.0	828.0	1.80	938.4	2.04	1380.0	3.00	8.52
2	1	2.50	0.350 X 0.452	9-3210-4	387.0	1451.3	0.38	1644.8	0.43	2418.8	0.63	1.81
		3.00		9-3212-4	312.0	1404.0	0.45	1591.2	0.51	2340.0	0.75	2.16
		3.50		9-3214-4	254.4	1335.6	0.53	1513.7	0.60	2226.0	0.88	2.51
		4.00		9-3216-4	220.0	1320.0	0.60	1496.0	0.68	2200.0	1.00	2.86
		4.50		9-3218-4	189.7	1280.5	0.68	1451.2	0.77	2134.1	1.13	3.21
		5.00		9-3220-4	172.8	1296.0	0.75	1468.8	0.85	2160.0	1.25	3.56
		6.00		9-3224-4	141.6	1274.4	0.90	1444.3	1.02	2124.0	1.50	4.24
		8.00		9-3232-4	101.5	1218.0	1.20	1380.4	1.36	2030.0	2.00	5.64
		10.00		9-3240-4	84.0	1260.0	1.50	1428.0	1.70	2100.0	2.50	7.02
12.00	9-3248-4	70.0	1260.0	1.80	1428.0	2.04	2100.0	3.00	8.35			

* **NOTE:** For design purposes only. We do not recommend deflecting a spring to maximum deflection.

SPRING ACCESSORIES

SPRING CAGES

Our spring cages enhance die spring life by providing a flat, hardened die pocket for spring operation.

Material: A513 tube steel

Conforms to NAAMS standards.

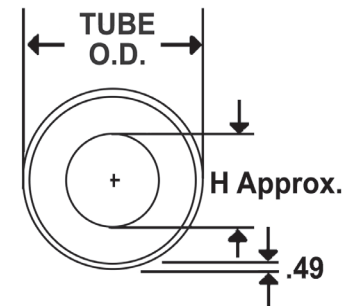
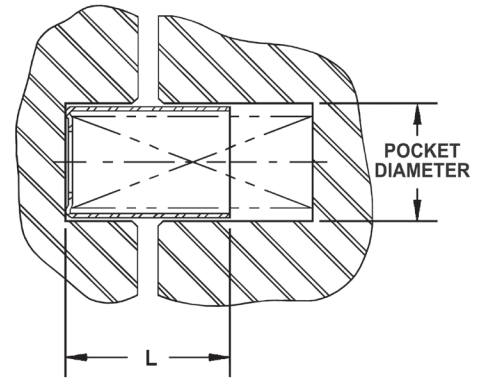

Spring Diameter (in)	Pocket Diameter (in)	Tube O.D. (in)	Diameter (H) (in)
3/4	29/32	0.855	7/16
1	1 5/32	1.105	9/16
1 1/4	1 13/32	1.355	3/4
1 1/2	1 21/32	1.605	31/32
2	2 5/32	2.105	1 3/8

Length L (in)	3/4 inch Diameter Springs		1 inch Diameter Springs		1 1/4 inch Diameter Springs		1 1/2 inch Diameter Springs		2 inch Diameter Springs	
	CATALOG NUMBER	NAAMSCATALOG Code	NAAMSCATALOG NUMBER	NAAMSCATALOG Code	NAAMSCATALOG NUMBER	NAAMSCATALOG Code	NAAMSCATALOG NUMBER	NAAMSCATALOG Code	NAAMSCATALOG NUMBER	NAAMSCATALOG Code
1	6-8	S212025	8-8	S212525	10-8	S213225	12-8	S214025	16-8	S215025
1 1/4	6-10	S212032	8-10	S212532	10-10	S213232	12-10	S214032	16-10	S215032
1 1/2	6-12	S212038	8-12	S212538	10-12	S213238	12-12	S214038	16-12	S215038
1 3/4	6-14	S212044	8-14	S212544	10-14	S213244	12-14	S214044	16-14	S215044
2	6-16	S212051	8-16	S212551	10-16	S213251	12-16	S214051	16-16	S215051
2 1/4	6-18	-	8-18	-	10-18	-	12-18	-	16-18	-
2 1/2	6-20	S212064	8-20	S212564	10-20	S213264	12-20	S214064	16-20	S215064
2 3/4	6-22	-	8-22	-	10-22	-	12-22	-	16-22	-
3	6-24	S212076	8-24	S212576	10-24	S213276	12-24	S214076	16-24	S215076
3 1/4	6-26	-	8-26	-	10-26	-	12-26	-	16-26	-
3 1/2	6-28	S212089	8-28	S212589	10-28	S213289	12-28	S214089	16-28	S215089
3 3/4	6-30	-	8-30	-	10-30	-	12-30	-	16-30	-
4	6-32	S212010	8-32	S212510	10-32	S213210	12-32	S214010	16-32	S215010
4 1/4	6-34	-	8-34	-	10-34	-	12-34	-	16-34	-
4 1/2	6-36	-	8-36	-	10-36	-	12-36	-	16-36	-
4 3/4	6-38	-	8-38	-	10-38	-	12-38	-	16-38	-
5	6-40	S212012	8-40	S212512	10-40	S213212	12-40	S214012	16-40	S215012
5 1/2	6-44	-	8-44	-	10-44	-	12-44	-	16-44	-
6	6-48	S212015	8-48	S212515	10-48	S213215	12-48	S214015	16-48	S215015
6 1/2	6-52	-	8-52	-	10-52	-	12-52	-	16-52	-
7	6-56	S212017	8-56	S212517	10-56	S213217	12-56	S214017	16-56	S215017
8	6-64	S212020	8-64	S212520	10-64	S213220	12-64	S214020	16-64	S215020
9	-	-	-	-	10-72	S213222	12-72	S214022	16-72	S215022
10	-	-	-	-	10-80	-	12-80	-	16-80	-
11	-	-	-	-	-	-	-	-	16-88	S215028
12	-	-	-	-	-	-	-	-	16-96	S215030

SPRING ACCESSORIES

SPRING RETAINERS

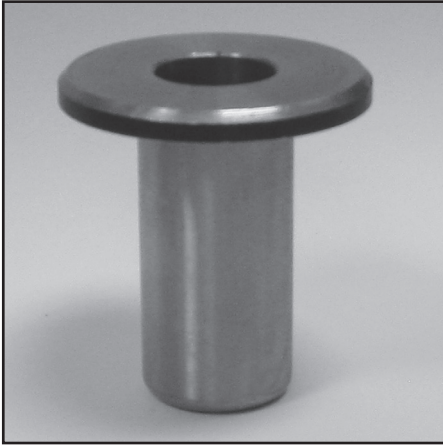

Our spring retainers hold individual springs firmly in position while the die is being assembled or disassembled. Pre-loading the spring is easy since the springs can be set individually, which avoids working against the combined force of the springs.

Available for springs 1 1/4" (32mm), 1 1/2" (38mm) and 2" (50mm) diameters and any free length where clearance permits.

Material: steel

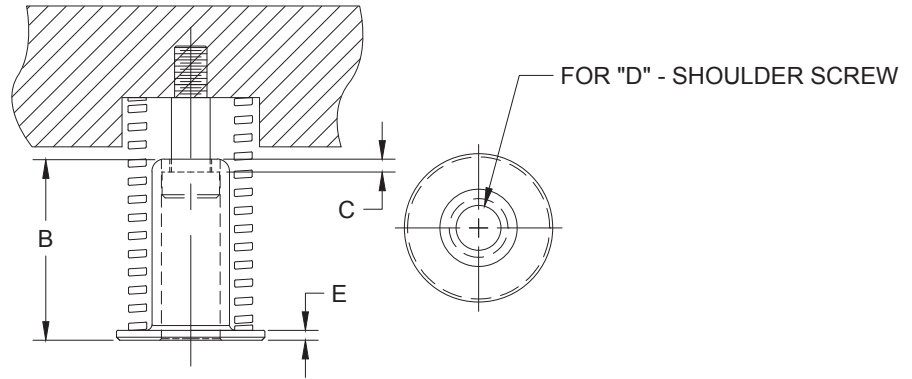

Catalog Number	Spring Diameter		Rod Diameter A		B		C		Shoulder Screw D		E	
	in	mm	in	mm	in	mm	in	mm	in	mm	in	mm
SR125150	1-1/4	32	5/8	16	1-11/16	43	0.19	4.8	5/16	-	0.19	4.8
SR125200					2-3/16	56	0.19	4.8	5/16	-	0.19	4.8
SR125250					2-11/16	68	0.19	4.8	5/16	-	0.19	4.8
SR150150	1-1/2	38	3/4	19	1-11/16	43	0.19	4.8	3/8	M8	0.19	4.8
9-0615-16					1-7/8	48	0.125	3.2	3/8	M8	0.096	2.4
SR150200					2-3/16	56	0.19	4.8	3/8	M8	0.19	4.8
SR150250					2-11/16	68	0.19	4.8	3/8	M8	0.19	4.8
SR200150	2	50	1	25	1-11/16	43	0.19	4.8	1/2	M13	0.19	4.8
9-0815-16					1-7/8	48	0.125	3.2	1/2	M13	0.125	3.2
SR200200					2-3/16	56	0.19	4.8	1/2	M13	0.19	4.8
SR200250					2-11/16	68	0.19	4.8	1/2	M13	0.19	4.8
9-0823-16					2-7/8	73	0.125	3.2	1/2	M13	0.125	3.2

SPECIALTY ITEMS

ACCU-BEND™ ROTARY BENDERS

SIMPLIFYING YOUR BENDING PROCESS WITH ACCU-BEND™ ROTARY BENDERS!



Accu-Bend™ units include a tool steel Rocker set into a steel Saddle with a graphite plugged Aluminum-Bronze liner. Available in standard inch and metric sizes with Rocker diameters of 20mm–115mm (0.75" – 4.5") and lengths of 50mm–900mm (2.0" – 35.0"), these units transfer the vertical motion of the press into a smooth one-motion rotation. The smooth rotation provides a rotary bend process which requires less tonnage and less strain on the material. The Accu-Bend™ Rotary Bender can also include optional pre-configured mounting hole patterns.

The saddle liner is a bronze alloy chosen for the ability to hold up to a bearing load with little to no wear while the graphite plugs are included in the bronze liner to provide lubrication. Both Rockers and Saddles are machined for precision and interchangeability. Compact benders fit in tight places and are ideal for bending small tabs within a larger part. Specials can be manufactured for your custom needs as well when an off-the-shelf product doesn't work for your application.

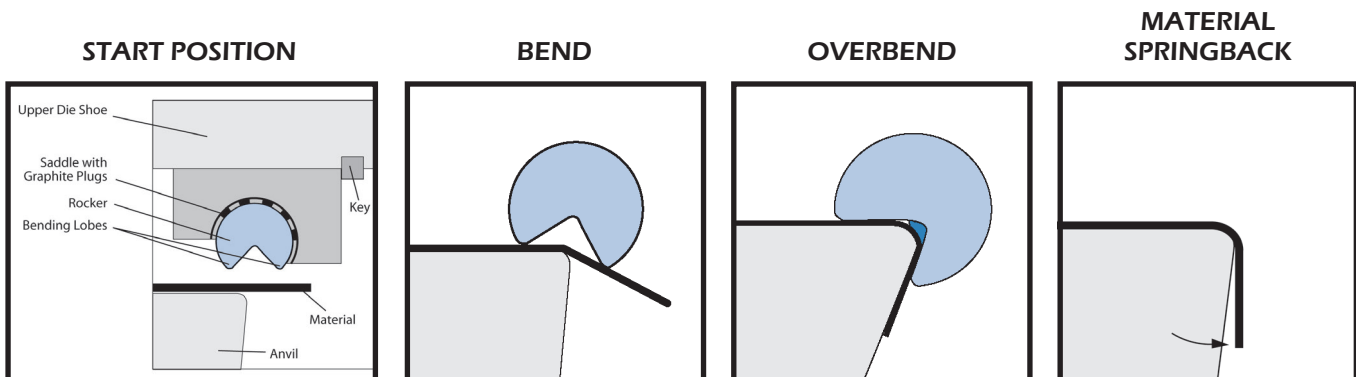

Holds $\pm 1/2$ degree angle tolerance

Bends angles up to 120° for special part design and pre-hem applications

Decreases forming tonnage by 40 – 80% over wipe tooling and "V" dies

Forms channel bends in one hit by pairing two bends together

FORMATHANE® URETHANE

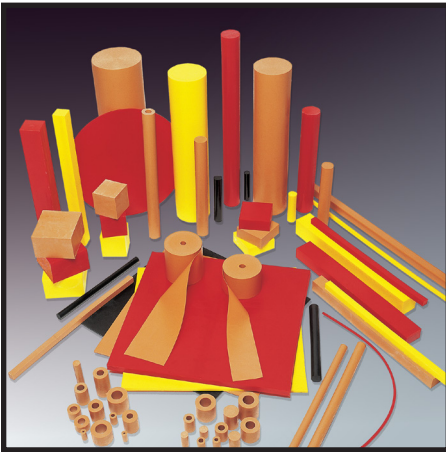

The Formathane® product line of urethane bars, rods, sheets, springs, film and strippers stands alone when compared to other urethane products offered in the market. Formathane® is formulated with the metalforming and fabricating user in mind to withstand the rigors of these difficult environments. Every day customers are putting it to the test and are finding double and triple life expectancies are more the norm than the exception with Formathane®. The higher than average performance is due to using premium grade urethane compounds, computer controlled production methods and stringent quality standards. Often used for springs, strippers, wear pads, vibration dampening, forming and part protection, Formathane® is offered in four durometers from 70 – 95A.

JIS SPRINGS



As a manufacturer of high quality springs in all standard ISO sizes, we also have available a line of true metric springs, in all the standard JIS (Japanese Industrial Standards) sizes and color load ratings. This extension of the spring line gives more options to customers with exacting requirements, making them available from the same reliable source as the inch springs. Manufactured in an optimal rectangular design and from a high strength chromium alloy material, these springs provide stability between load deflection and cycle life. The JIS product offering includes over 1,000 part numbers divided into five duty groups (colors), with fourteen diameters available per diameter and free lengths from 20mm to 300mm.

PUNCHES



We offer a comprehensive range of standard punches and die buttons in the basic, ball lock and variable precision series. Each component is made of quality heat treated tool steel which meets or exceeds ANSI standards. They are available in A2 high performance tool steel for toughness and economy, and M2, high speed steel, triple-tempered for long runs where abrasion resistance is required. Also available as a special option is PM4 which offers improved wear and impact characteristics ideal for optimum performance at high operating speeds.

SPECIALTY ITEMS

MISCELLANEOUS

SURFACE MOUNT BALL BEARING ASSEMBLIES



LEMPCO now offers a new low cost ball bearing component assembly alternative added to our die components guiding system product line. These new additions, Surface Mount Ball Bearing Assemblies, are mounted directly to the die holder and punch holder rather than the conventional method. These assemblies are available in 32mm, 38mm, 50mm and 60mm diameters, while lengths range from 100mm to 350mm, depending on diameter. Complete assemblies will include the necessary mounting bolts and dowel pins required for installation as well as optional tapped mounting holes to secure Stroke End Blocks. Surface Mount Ball Bearing Assemblies are available as stand-alone assemblies.

DIE ACCESSORIES



A complete line of inch and metric pressroom accessories, including fasteners, hoist rings, stripper bolts, punch holder shanks, roller stock guides, stock pushers, pry bars, ball bearing and die lubrication and pad retainers are available. With parts manufactured from heat-treated, high strength alloy steel and machined to precise tolerances, you can be sure they are inspected to assure uniform hardness, quality and dimensions.

SPECIALS TO MEET YOUR EXACT NEEDS

LEMPCO customization services will go to virtually any length to satisfy your needs. Now, the full range of answers to your requirements is at your command. It could be a simple modification or something quite exotic. Whatever your need, LEMPCO will work closely with you to select, design and manufacture products to meet your demands, while providing cost-effective solutions.

COMPONENTS MANUFACTURING CAPABILITIES:

Finished outside diameters from 5/8" x 15" (15.9mm x 381mm) length to 5" x 60" (127mm x 1524mm) length

Finished inside diameters

- ▶ Hardened Steel – 1/2" x 4" (12.7mm x 102mm) length to 3 5/8" x 14" (92mm x 356mm) length
- ▶ Bronze Plated Steel – 1/2" x 4" (12.7mm X 102mm) length to 4 1/2" x 9" (114mm x 228mm) length
- ▶ Solid Bronze (w/wo graphite plugs) – 5/8" x 4" (16mm x 102mm) length to 6 1/8" x 7 7/8" (156mm x 200mm) length

3-Axis milling with part lengths up to 48" (1219mm)

5-Axis prismatic machining

Surface grinding up to 96" (2438mm) length x 17" (431mm) wide

Hard turning

- ▶ Maximum outside diameter: 3 3/4" (95mm)
- ▶ Minimum inside diameter: 1/2" (12.7mm)

Heat treating – alloy and low carbon steels up to 62HRC (size and carbon content dependent)

Induction hardening

- ▶ 1050 steel, up to 5 1/4" (133mm) diameter and hardened to 58/62 HRC
- ▶ 52100 steel, up to 3 3/4" (95mm) diameter and hardened to 58/62 HRC

CMM Machine

- ▶ Calypso programming software to quickly measure simple and complex parts, based on a CAD model or free form measurement
- ▶ Part weight capacity up to 3520 lbs.
- ▶ Measuring range (XYZ) – 39.4" x 63" x 23.6"
- ▶ Clearance under bridge – 29"

PLATING SERVICES AVAILABLE:

Chrome Plating

Copper Bronze Plating

SPRINGS MANUFACTURING CAPABILITIES:

Outside diameters from 3/16" to 9 1/2" (4.8mm to 241mm)

Free lengths from 1/2" to 90" (12.7mm to 2286mm)

Round spring wire from 0.014" to 1.625" (.36mm to 41.3mm)

Standard rectangular wire up to 0.408" x 0.469" (10.4mm x 11.9mm)

SPRING COATINGS AVAILABLE:

Plain, no paint

Oiled

Electroless Nickel

Chrome

Zinc

Powder or E-coat paint

Mil-spec coatings

Cadmium

Dacromet®

Others on request

High quality products, service and innovative development are key elements in our continued dedication to serving the needs of our customers.

LEMPCO®



www.daytonlamina.com